



Table of Contents

5HP19FLA Transmission Overview (North American Applications)	
Make / Model / Model Year	2
5HP19FLA Technical Information	
Torque, Gear Ratio & Weight	3
Transmission Oil Reference Guide	3
5HP19FLA Lubrications	3
5HP19FLA Technical Literature	3
5HP19FLA General Transmission Oil Filling Procedure	4
5HP19FLA General Differential Oil Filling Procedure	6
5HP19FLA General Transfer Case Oil Filling Procedure	7
5HP19FLA Spare Parts	
How To Use This Catalog	8
Gearbox Housing Group	9
Oil Sump Group	12
Oil Supply Group	13
Converter Group	15
Planetary Drive Groups	16
Front Axle Differential Group	18
Rear Axle Output Group	21
Front Axle Output Group	23
Internal Differential Lock Group	24
Clutch Pack Groups	25
5HP19FLA Valve Body	
Duct Plate Group	31
Valve Housing Groups	35
5HP19FLA Selective Shims, Snap Rings & Kit Content	
5HP19FLA Selective Shims & Snap Rings	46
5HP19FLA Kit Content	53
Miscellaneous	
Quotation / Order Form	57
Notes	58



5HP19FLA Transmission Overview (North American Applications)

Make / Model / Model Year – Audi

Make	Model	Style	Model Year	From – Up to	Code	OE Part #	ZF Part #
Audi	A4	Quattro 1.8 Liter	1998 – 2002	08/97 – 12/98	DTV	01V 300 043H	1060 040 018
			2000	08/99 – 05/00	EFQ	01V 300 044G	1060 040 030
			2000 – 2001	05/00 – 10/00	FAL	01V 300 049F	1060 040 054
			2002 – 2003	09/01 – 06/02	FEP	01V 300 045Q	1060 040 073
			2002 – 2003	07/02 –	GBF	01V 300 052Q	1060 040 101
Audi	A4	Quattro 2.8 Liter	1996 – 1997	10/95 – 04/97	CJP	01V 300 041G	1060 040 002
			1998 – 1999	08/97 – 12/98	DRN	01V 300 043A	1060 040 012
			1999 – 2000	08/99 – 05/00	EKD	01V 300 046H	1060 040 035
			2000 - 2001	06/00 – 08/01	FAS	01V 300 049M	1060 040 065
Audi	A4	Quattro 3.0 Liter	2002 – 2003	09/01 – 06/02	FEQ	01V 300 045T	1060 040 087
			2002 – 2003	07/02 –	GBJ	01V 300 052T	1060 040 103
Audi	S4	Quattro 2.7 Liter	1999 – 2002	08/99 – 05/00	EMP	01V 300 046T	1060 040 044
Audi	A6	Quattro 2.7 Liter	1998 – 2000	05/99 – 05/00	EMP	01V 300 046T	1060 040 044
			2000 – 2001	06/00 – 05/01	FAQ	01V 300 049K	1060 040 063
Audi	A6	Quattro 2.8 Liter	1998 – 1999	08/97 – 07/98	DPT	01V 300 042Q	1060 040 013
			1999	02/99 – 07/99	EKX	01V 300 046K	1060 040 036
			2000	08/99 – 05/00	EKD	01V 300 046H	1060 040 035
			2000 – 2001	06/00 – 05/01	FAS	01V 300 049M	1060 040 065
Audi	A6	Quattro 3.0 Liter	2002 – 2003	06/01 –	FEJ	01V 300 050K	1060 040 075
Audi	Allroad	Quattro	2002 – 2003	09/02 –	FXL	01V 300 052N	1060 040 093
Audi	Allroad	Quattro 2.7 Liter	2000 – 2003	05/00 – 06/02	EYK	01V 300 050A	1060 040 053

Make / Model / Model Year – VW

Make	Model	Style	Model Year	From – Up to	Code	OE Part #	ZF Part #
VW	Passat	Sedan 2.8L (4-Motion)	1999 – 2001	06/98 – 04/99	DRN	01V 300 043A	1060 040 012
			2000	08/99 – 05/00	EKD	01V 300 046H	1060 040 035
			2001 – 2003	03/01 – 04/02	FAS	01V 300 049M	1060 040 065
VW	Passat	Sedan 4.0L (4-Motion)	2002 – 2003	12/01 – 04/02	GAK	01V 300 052P	1060 040 100

Note: This spare parts catalog includes only transmission specification numbers for North American applications. For all other 5HP19FLA transmission specification numbers, please contact your preferred ZF passenger car transmission distributor for more information about available spare parts and kits.

Type Plate: One type plate is located on the main housing of transmission; second type plate located on bottom of bell housing. Please refer to ZF transmission specification # when searching for spare parts and kits in this catalog (last three digits).



- ← Transmission Serial #
- ← ZF Transmission Specification #
- ← Vehicle Manufacturer Transmission #



5HP19FLA Technical Information

Torque, Gear Ratio & Weight

Input Torque	1 st Gear	2 nd Gear	3 rd Gear	4 th Gear	5 th Gear	Rev Gear	Weight (approximate)	Oil Capacity (approximate)
420 Nm	3.57	2.20	1.51	1.00	0.80	4.10	~142 kg (312 lbs.)	~9.5 liter (10.1 quart)

Transmission Oil Reference Guide

Make	Oil Grade	Type Plate (color)	ZF Part #	OE Part #
Audi	ESSO LT 71141	Green	1060 040 002	01V 300 041G
			1060 040 012	01V 300 043A
			1060 040 013	01V 300 042Q
			1060 040 018	01V 300 043H
			1060 040 030	01V 300 044G
			1060 040 035	01V 300 046H
			1060 040 036	01V 300 046K
			1060 040 044	01V 300 046T
			1060 040 053	01V 300 050A
			1060 040 054	01V 300 049F
			1060 040 063	01V 300 049K
			1060 040 065	01V 300 049M
			1060 040 073	01V 300 045Q
			1060 040 075	01V 300 050K
			1060 040 087	01V 300 045T
			1060 040 093	01V 300 052N
1060 040 101	01V 300 052Q			
1060 040 103	01V 300 052T			
VW	ESSO LT 71141	Green	1060 040 012	01V 300 043A
			1060 040 035	01V 300 046H
			1060 040 065	01V 300 049M
			1060 040 100	01V 300 052P

5HP19FLA Lubrications

Amount	ZF Part #	Description	Where used (1060 040 ____)	Notes
10 Liter	0671 090 162	Oil BURMAH SAF AG4 (Canister)	All	Use only in differential and transfer case
20 Liter	0671 090 166	Oil ESSO LT 71141 (Canister)	All	Use only in transmission
205 Liter	0671 090 169	Oil ESSO LT 71141 (Drum)	All	Use only in transmission
10 Liter	S671 600 020	Oil STURACO FM 1992	All	Use only in transfer case
0.050 Liter	V671 600 020	Oil STURACO FM 1992	All	Use only in transfer case

5HP19FLA Technical Literature

Language	ZF Part #	Description	Where used (1060 040 ____)	Notes
English	5HP19FLFD	5HP19FLA Functional Description	All	
English	5HP19FLREP	5HP19FLA Repair Manual	All	
Eng/Ger	1060 764 002	5HP19FLA Wall Chart	All	
English	5HPVBMAN	5-Speed Valve Body Manual	All	



5HP19FLA Technical Information

5HP19FLA General Transmission Oil Filling Procedure

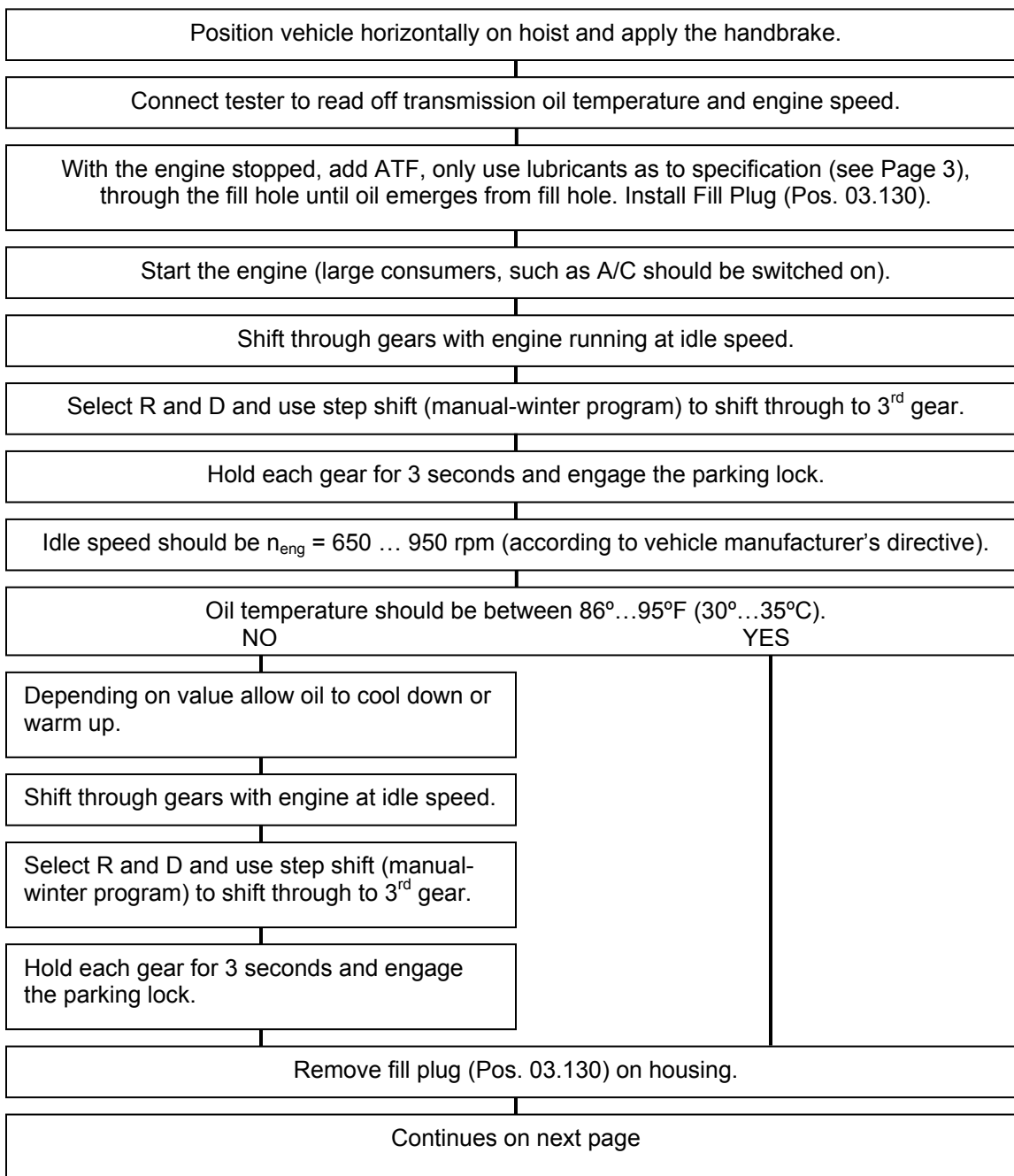



5HP19FLA Technical Information

5HP19FLA General Transmission Oil Filling Procedure (continued)

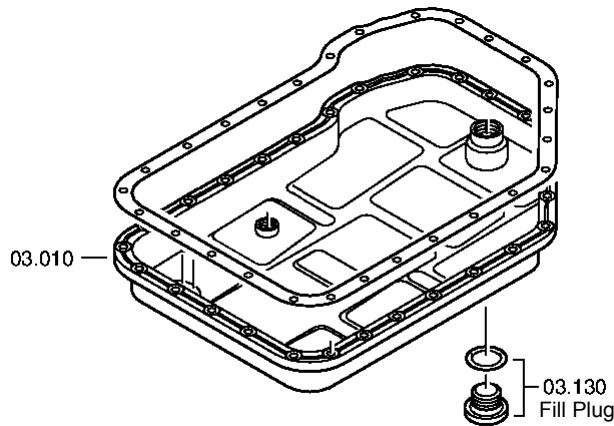
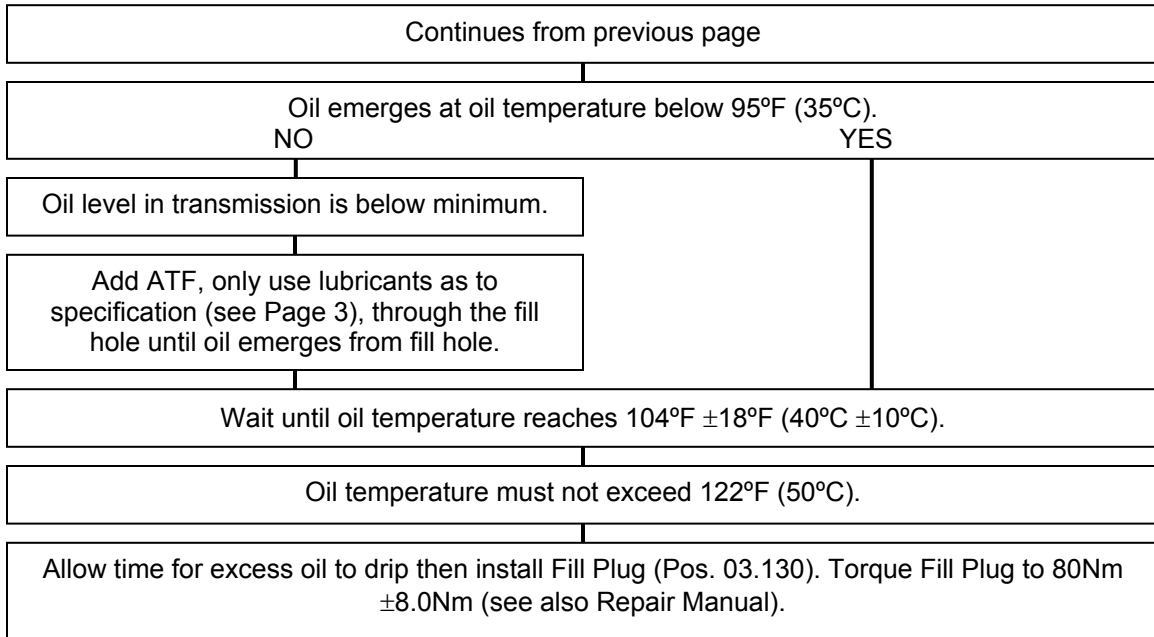



5HP19FLA Technical Information

5HP19FLA General Differential Oil Filling Procedure

Adding oil to 5HP19FLA differential.
Oil is added to the cold differential, approximately 68°F (~20°C), until it overflows.
Allow time for excess oil to drip then install differential fill plug (Pos. 35.370). Torque fill plug to 35Nm ±83.5Nm (see also Repair Manual).
Oil capacity is approximately 0.82 liter (~0.87 quart). Only use lubricants as to specification (see Page 3).

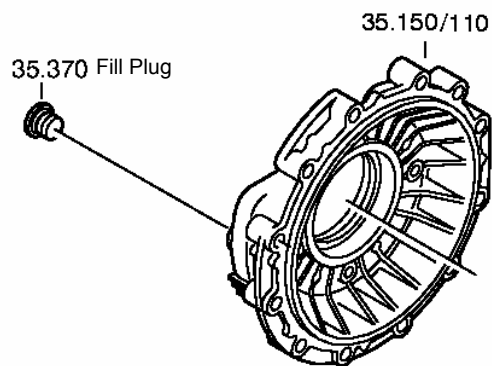



5HP19FLA Technical Information

5HP19FLA General Transfer Case Oil Filling Procedure

Adding oil to 5HP19FLA transfer case (Parallel Axis Torsen – PAT) with separate oil content.
Oil is added to the cold differential, approximately 68°F (~20°C), until it overflows.
Allow time for excess oil to drip then install transfer case fill plug (Pos. 36.350). Torque fill plug to 35Nm ±3.5Nm (see also Repair Manual).
Oil capacity is approximately 0.80 liter (~0.85 quart). Only use lubricants as to specification (see Page 3).

Note: The addition of 0.034 liter (~0.036 quart) Sturaco FM 1992 (see Page 3) is only necessary after a transfer case repair or renewal (exchange) of the Torsen differential. After installation in the transfer case, it is added in a vertical position and in a direct axial direction to the Torsen differential.

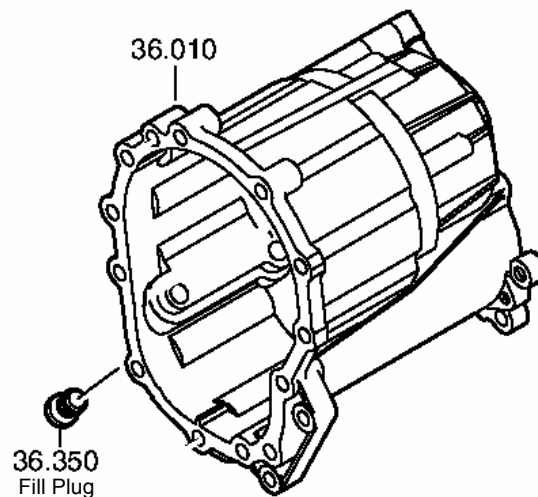



How To Use This Catalog

Table of Contents

Each transmission group of this catalog is listed in the table of contents. This spare parts catalog includes only transmission specification numbers for North American applications.

Technical Information

All technical information is specific to the transmission models that are referenced in this catalog. Weight and oil capacity information are only approximate and may vary by actual transmission specification. For any technical inquiry, please contact your preferred ZF passenger car transmission distributor for assistance. For a list of technical literature available from ZF or for answers to frequently asked questions about ZF transmissions visit us at www.zf-group.com.

Spare Parts

Each transmission is divided into groups (e.g. gearbox housing group). The position number (**Pos #**) is used to identify the location of each spare part in the transmission. A position number like 01.010 is either a spare part or an assembly. A position number like 01.010/110 is a subcomponent of an assembly. Please contact your preferred ZF passenger car transmission distributor about availability of assemblies and subcomponents.

The part number (**ZF part #**) is used to identify a specific spare part and is usually ten-digits (kits, lubricants, and technical literature have exceptions). Please use this part number, when ordering ZF spare parts.

The description (**Description**) identifies the spare part.

The quantity (**Qty**) is the amount of spare parts included in one transmission model for a certain position number. The quantity may vary depending on the transmission specification and certain spare parts may be used in multiple positions in the transmission.

This catalog includes only spare parts for North American specifications of a ZF transmission application. The “where used” column (**Where used (10_ 000 __)**) shows the last three digits of the transmission specification that uses the listed spare part. If the column indicates “All”, then all North American transmission specification use this spare part.

The notes column (**Notes**) gives more information about the spare part (e.g. included in a kit).

Example:

Pos #	ZF Part #	Description	Qty	Where used (1056 000 __)	Notes
01.010	1056 201 084	Gearbox Housing	1	087/088	
	1056 201 087	Gearbox Housing	1	081	
01.010/110	1056 301 174	Gearbox Housing	1	087/088	
	1056 301 175	Gearbox Housing	1	081	

Selective Shims, Snap Rings & Kit Content

Each list for selective shims or snap rings is listed in this section of the catalog. Please measure the clearance according to the repair manual and select the required spare part from the table.

The kit content section shows all available kits for the transmission models that are referenced in this catalog, including the content of each kit.



5HP19FLA Spare Parts - Gearbox Housing Group

Pos #	ZF Part #	Description	Qty	Where used (1060 040 ___)	Notes
01.010	1060 201 066	Gearbox Housing	1	002/012/013/018/030/ 035/036/044/054/063/ 065/075	
	1060 201 076	Gearbox Housing	1	053	
	1060 201 078	Gearbox Housing	1	100	
	1060 201 082	Gearbox Housing	1	073/087/101/103	
	1060 201 098	Gearbox Housing	1	093	
01.010/110	1060 301 100	Gearbox Housing	1	002/012/013/018/030/ 035/036/044/054/063/ 065/075	
	1060 301 111	Gearbox Housing	1	100	
	1060 301 112	Gearbox Housing	1	053	
	1060 301 120	Gearbox Housing	1	073/087/101/103	
01.010/130	0734 313 060	O-Ring	2	All	* Available in kit 1060 298 031
01.010/140	1056 301 140	Oil Tube	1	All	
01.020	1060 301 017	Pin	1	All	
01.030	1060 324 006	Pawl	1	All	
01.040	1060 324 004	Leg Spring	1	All	
01.050	1060 201 005	Connecting Bar	1	All	
01.060	1060 324 007	Guiding Plate	1	All	
01.080	0736 617 074	Torx Screw M8x30	3	All	
01.100	0630 504 003	Locking Washer	1	All	
01.120	0501 314 432	Speed Sensor	1	All	
01.130	1056 301 094	Spacer Ring	1	All	
01.140	0736 101 131	Torx Screw M6x27	1	All	
01.180	1060 206 023	Detent Spring	1	All	
01.180/120	1060 306 007	Roller	1	All	
01.200	0736 101 240	Torx Screw M6x13	2	All	

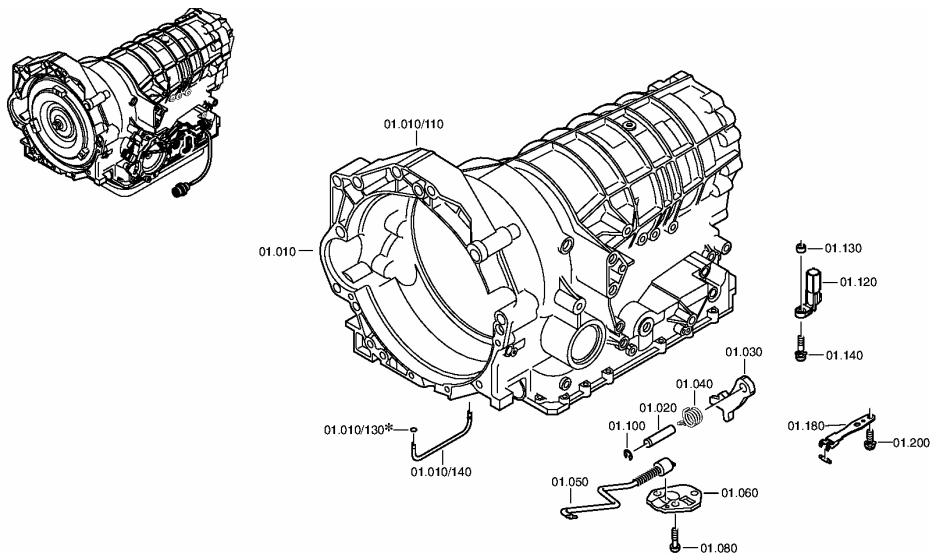

Note: Parts marked with * are only available in kits.



5HP19FLA Spare Parts - Gearbox Housing Group (continued)

Pos #	ZF Part #	Description	Qty	Where used (1060 040 ___)	Notes
01.210	1060 206 021	Selector Shaft	1	All	
01.210/110	1056 306 043	Selector Shaft	1	All	
01.210/120	1060 206 017	Gear Shift Lever	1	All	
01.210/130	0501 320 396	Clamping Sleeve	1	All	
01.220	1060 206 015	Detent Disc	1	All	
01.230	0501 320 396	Clamping Sleeve	1	All	
01.250	0734 319 624	Shaft Seal	1	All	* Available in kit 1060 298 031
01.260	0501 318 572	Screw Plug M10x1	1	All	* Available in kit 1060 298 031
01.270	0734 317 268	Sealing Sleeve	5	All	* Available in kit 1060 298 031
01.280	0734 317 227	Sealing Sleeve	3	All	* Available in kit 1060 298 031
01.300	0732 041 746	Compression Spring	3	All	
01.310	0630 532 800	Retaining Ring	3	All	
01.320	1056 206 038	Selector Lever	1	All	
01.330	0501 320 396	Clamping Sleeve	1	All	
01.400	0501 209 896	Position Switch	1	002/012/013/018/030/ 035/036/044	
	0501 317 994	Position Switch	1	053/054/063/065/073/ 075/087/093/100/101/ 103	

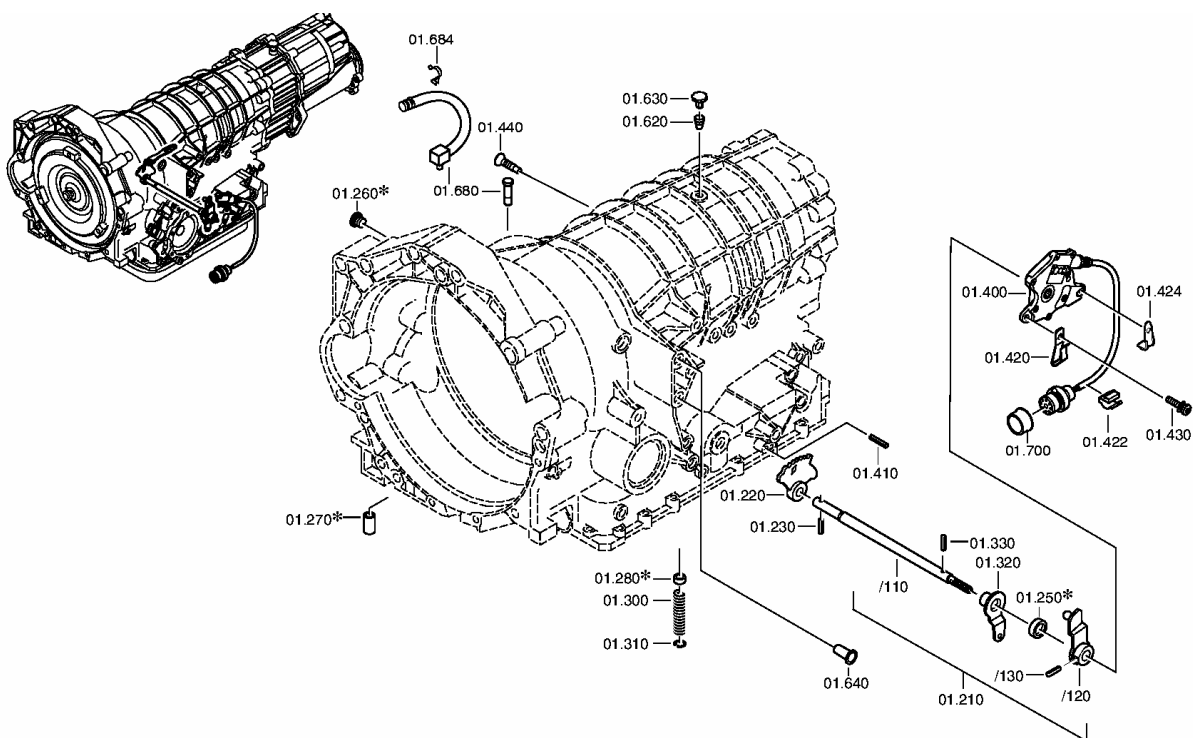

Note: Parts marked with * are only available in kits.



5HP19FLA Spare Parts - Gearbox Housing Group (continued)

Pos #	ZF Part #	Description	Qty	Where used (1060 040 ___)	Notes
01.410	0631 306 184	Cylindrical Pin	1	All	
01.420	0501 318 901	Cable Terminal	1	All	
01.422	0501 315 033	Terminal	1	073/087/101/103	
01.424	0501 318 899	Fixing Plate	1	All	
01.430	0736 101 233	Torx Screw M6x15	2	All	
01.440	0736 401 065	Counters. Screw M6x20	1	All	
01.620	0501 318 900	Breather Tube	1	All	
01.630	0501 314 809	Breather Cover	1	All	
01.640	0501 315 455	Plug	2	All	
01.680	0501 212 914	Breather	1	All (except 053/093)	
	1060 290 026	Breather	1	053/093	
01.684	0501 319 031	Cable Terminal	1	053/093	
01.700	0501 318 771	Protecting Cap	1	053/054/063/065/073/ 075/087/093/100/101/ 103	
	0637 900 038	Plug	1	002/012/013/018/030/ 035/036/044	

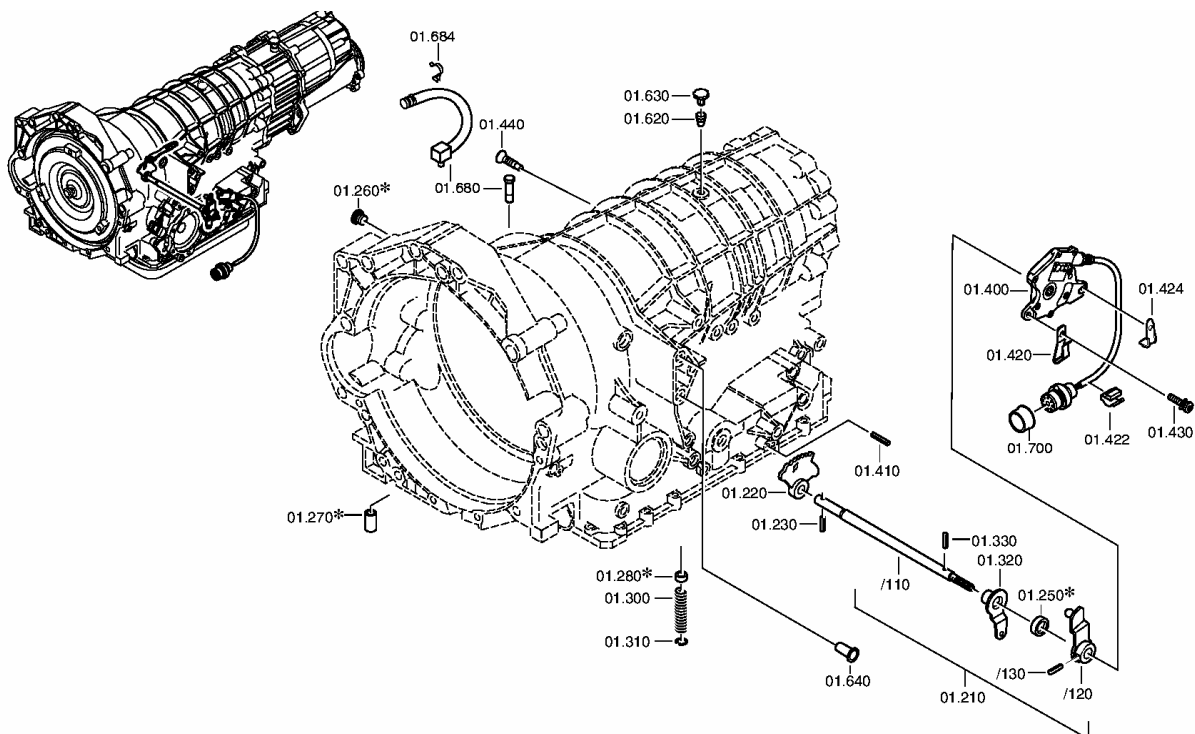

Note: Parts marked with * are only available in kits.



5HP19FLA Spare Parts – Oil Sump Group

Pos #	ZF Part #	Description	Qty	Where used (1060 040 ___)	Notes
03.010	1060 203 002	Oil Sump	1	All	
03.020	1056 303 031	Gasket	1	All	* Available in kit 1060 298 031 * Available in kit 5HP19FKFL
03.044	0736 101 318	Torx Screw M6x22	27	All	
03.070	1043 301 036	Magnet	4	All	
03.080	1043 301 036	Magnet	2	All	
03.100	1060 303 002	Cap	1	All	
03.120	0636 308 026	Screw Plug M6x1.5	1	All	* Available in kit 1060 298 031 * Available in kit 5HP19FKFL
03.130	0636 302 102	Screw Plug M30x1.5	1	All	* Available in kit 5HP19FKFL
	0734 313 176	O-Ring	1	All	* Available in kit 1060 298 031 * Available in kit 5HP19FKFL

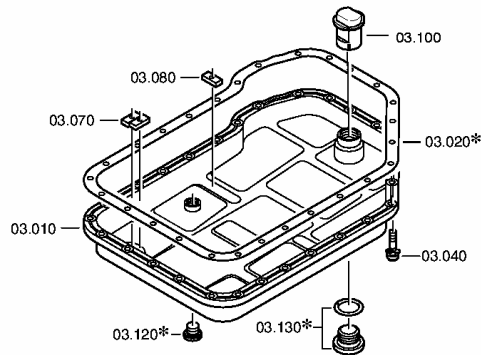
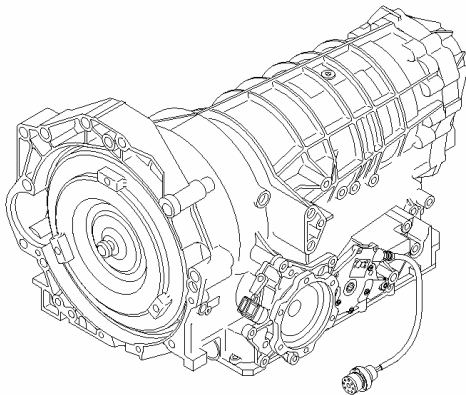

Note: Parts marked with * are only available in kits.



5HP19FLA Spare Parts - Oil Supply Group

Pos #	ZF Part #	Description	Qty	Where used (1060 040 ___)	Notes
10.010	1060 210 024	Pump	1	All	
10.010/120	1043 319 058	Sleeve	1	All	
10.010/150	1056 310 075	Washer	1	All	
10.010/160	0734 310 316	Shaft Seal	1	All	* Available in kit 1060 298 031
10.030	0734 313 178	O-Ring	1	All	* Available in kit 1060 298 031
10.040	1060 310 091	Intermediate Sheet	1	All	
10.060	1060 210 032	Intermediate Plate	1	All (except 093/100)	
	1060 210 035	Intermediate Plate	1	093/100	
10.060/110	1060 210 030	Intermediate Plate	1	093/100	
	1060 210 034	Intermediate Plate	1	All (except 093/100)	
10.060/130	0736 401 061	Counters. Screw M6x20	5	All	
10.100	0736 401 062	Counters. Screw M6x40	8	All	
10.120	0736 401 063	Counters. Screw M6x48	1	All	
10.160	0736 101 059	Torx Screw M5x55	1	All	
10.180	1060 310 105	Cylinder C	1	012/013/036/044/053/ 063/075/087/093/100/ 103	
	1060 310 106	Cylinder C	1	002/018/030/035/054/ 065/073/101	
10.190	0734 313 006	O-Ring	1	All	* Available in kit 1060 298 031
10.200	0734 313 117	O-Ring	1	All	* Available in kit 1060 298 031
10.210	1056 310 081	Piston	1	All	
10.220	0736 101 197	Torx Screw M5x14	3	All	
10.240	0501 315 929	Cup Spring	1	All	
10.250	1056 310 061	Stop-Ring	1	All	

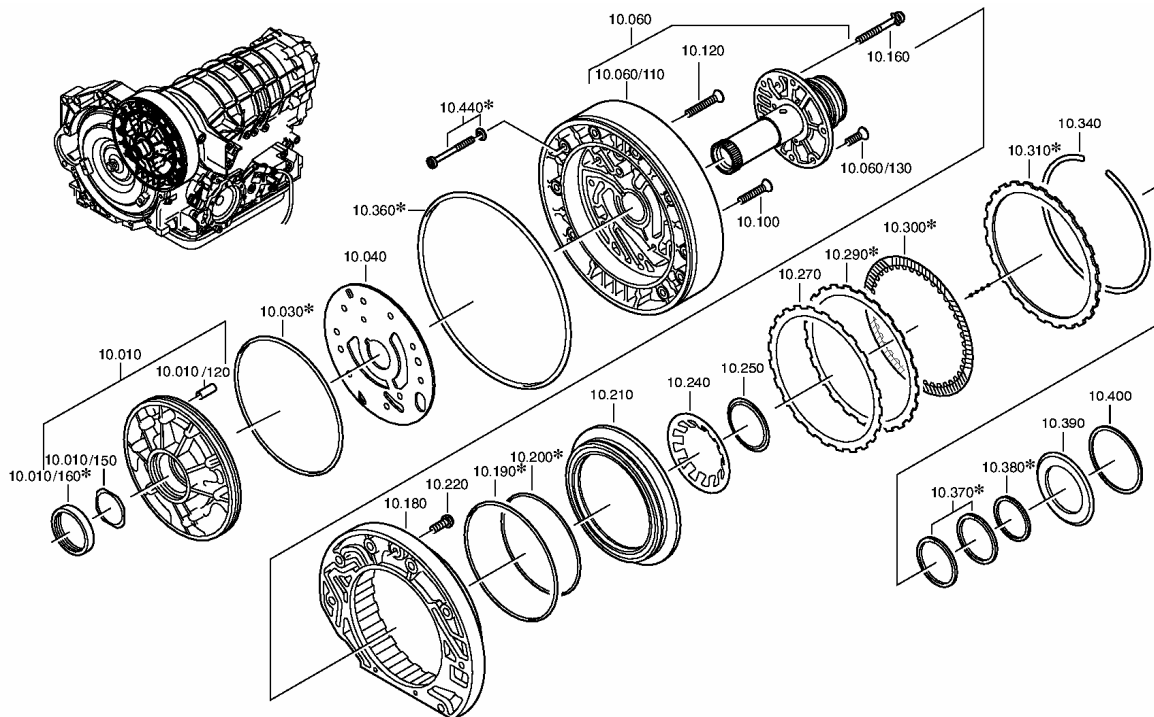

Note: Parts marked with * are only available in kits.



5HP19FLA Spare Parts - Oil Supply Group (continued)

Pos #	ZF Part #	Description	Qty	Where used (1060 040 ___)	Notes
10.270	0501 316 284	Undulated Spring	1	All	
10.290	1060 310 004	Steel Plate C	4	002/018	* Available in kit 1060 298 026
	1060 310 004	Steel Plate C	5	012/013/036/044/053/ 063/075/087/093/100/ 103	* Available in kit 1060 298 026
	1060 310 027	Steel Plate C	3	030/035/054/065/073/ 101	* Available in kit 1060 298 025
10.300	1019 273 019	Friction Plate C	4	002/018	* Available in kit 1060 298 024
	1019 273 019	Friction Plate C	5	012/013/036	* Available in kit 1060 298 024
	1060 210 037	Friction Plate C	3	030/035/054/065/073/ 101	* Available in kit 1060 298 022
	1060 210 037	Friction Plate C	5	044/053/063/075/087/ 093/100/103	* Available in kit 1060 298 022
10.310	1060 310 005	End Plate C	1	002/012/013/018/036/ 044/053/063/075/087/ 093/100/103	* Available in kit 1060 298 026
	1060 310 027	End Plate C	1	030/035/054/065/073/ 101	* Available in kit 1060 298 025
10.340	See Page 46	Clutch C Snap Ring	1	All	Selective Snap Ring
10.360	0734 313 162	O-Ring	1	All	* Available in kit 1060 298 031
10.370	0750 113 015	Piston Ring	2	All	* Available in kit 1060 298 031
10.380	0734 401 213	Piston Ring	1	All	* Available in kit 1060 298 031
10.390	0750 115 437	Axial Needle Bearing	1	All	
10.400	See Page 46	Intermediate Plate Shim	1	All	Selective Shim
10.440	0736 101 165	Torx Screw M6x65	9	All	
	0750 112 076	Usit Ring	9	All	* Available in kit 1060 298 031

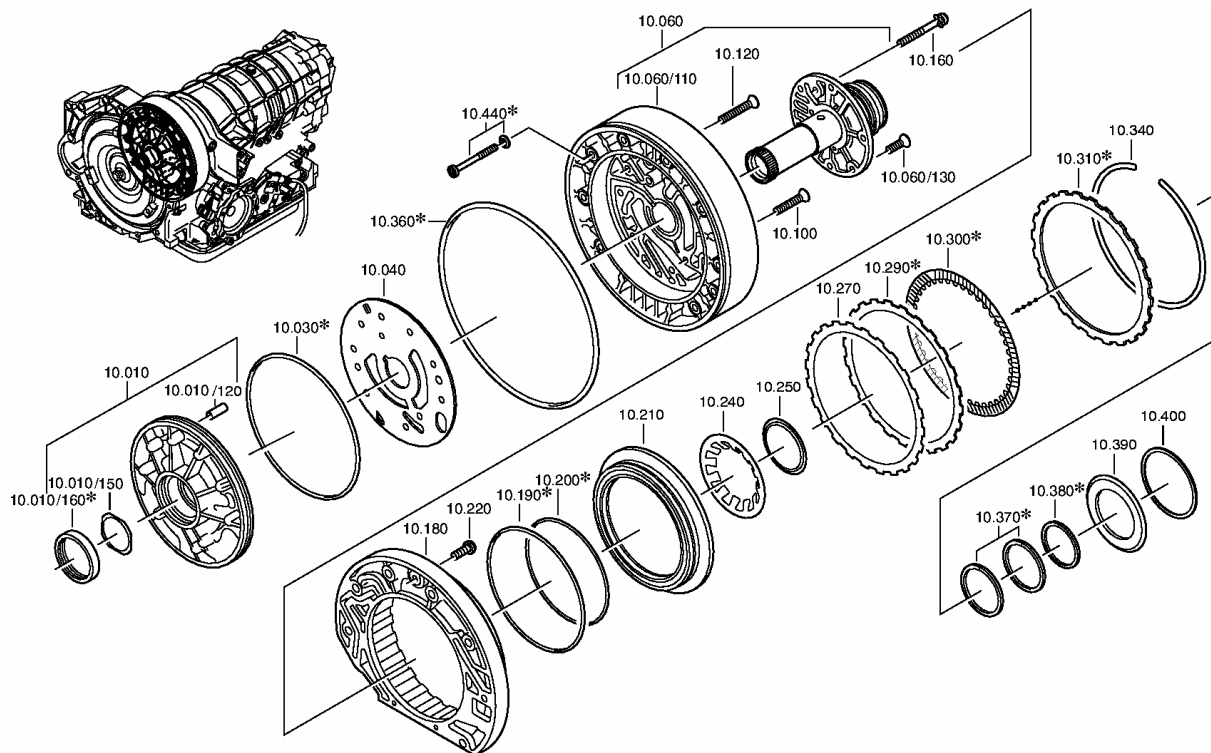

Note: Parts marked with * are only available in kits.



5HP19FLA Spare Parts – Converter Group

Pos #	ZF Part #	Description	Qty	Where used (1060 040 ___)	Notes
22.020	4168 025 046	Torque Converter N28	1	035/065	
	4168 025 063	Torque Converter F31	1	012/013/036	
	4168 025 069	Torque Converter A33	1	018/030/054/073/101	
	4168 025 085	Torque Converter F35	1	044/053/063/075/087/ 103	
	4168 025 127	Torque Converter T45	1	002	
	4168 025 186	Torque Converter Q56	1	100	
	4168 025 189	Torque Converter P56	1	093	

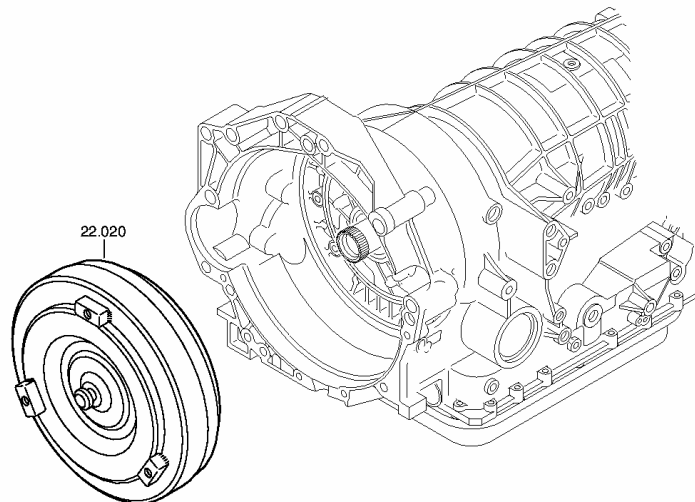

Note: Parts marked with * are only available in kits.



5HP19FLA Spare Parts – Planetary Drive Groups

Pos #	ZF Part #	Description	Qty	Where used (1060 040 ___)	Notes
32.020	1056 232 105	Bearing Set	1	All	
32.040	1056 232 089	Shaft	1	002/012/013/018/030/ 035/036/087/103	
	1060 232 026	Shaft	1	054/065/073	
	1060 232 048	Ring Gear	1	044/053/063/075/093/ 100	
32.040/110	1056 232 085	Shaft	1	002/012/013/018/030/ 035/036/054/065/073/ 087/101/103	
32.040/120	1056 332 037	Ring Gear	1	002/012/013/018/030/ 035/036/087/103	
	1060 332 028	Ring Gear	1	054/065/073	
32.040/130	0730 513 330	Snap Ring	1	002/012/013/018/030/ 035/036/054/065/073/ 087/101/103	
32.060	1056 232 104	Bearing Set	1	All	
32.074	1050 317 060	Spider Clutch Bell	1	030/035/044/053/054/ 063/065/073/075/087/ 093/100/101/103	
	1056 232 079	Spider Clutch Bell	1	002/012/013/018/036	
32.080	1050 232 052	Planet Carrier	1	002/012/013/018/030/ 035/036/044/053/063/ 075/087/093/100/103	
	1060 232 032	Planet Carrier	1	054/065/073/101	
32.090	1060 232 041	Sun Gear	1	054/065/073/101	
	1060 232 042	Sun Gear	1	030/035/044/053/063/ 075/087/093/100/103	
	1060 232 050	Sun Gear	1	002/012/013/018/036	
32.120	0735 368 043	Axial Needle Bearing	1	All	
32.140	1060 202 001	Sun Gear Shaft	1	All	
32.160	1056 232 101	Bearing Set	1	All	
32.180	1056 232 071	Intermediate Shaft	1	All	
32.200	1056 232 099	Bearing Set	1	All	

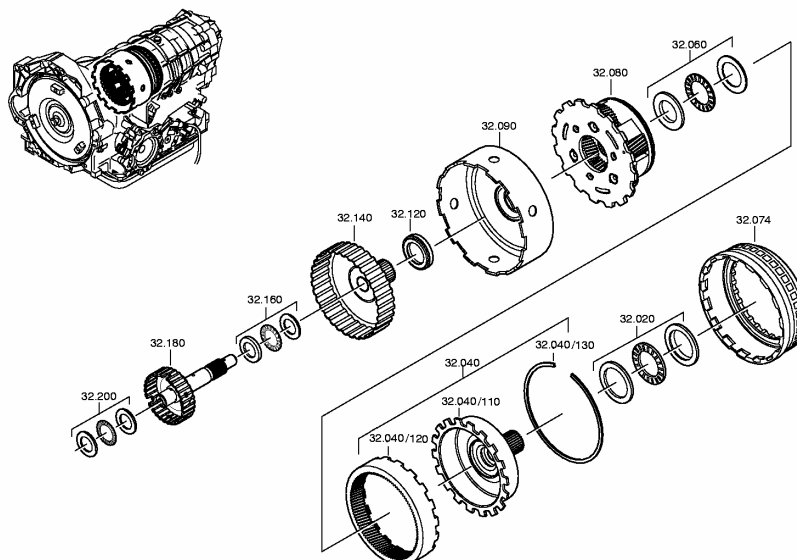

Note: Parts marked with * are only available in kits.



5HP19FLA Spare Parts – Planetary Drive Groups (continued)

Pos #	ZF Part #	Description	Qty	Where used (1060 040 ___)	Notes
42.010	1060 242 015	Planet Carrier	1	All	
42.030	1056 242 039	Bearing Set	1	All	
42.050	1056 232 083	Sun Gear	1	All	
42.120	1056 242 038	Bearing Set	1	All	
42.140	1056 242 041	Ring Gear	1	All	
42.140/110	1056 242 017	Ring Gear Carrier	1	All	
42.140/120	1056 332 010	Ring Gear	1	All	
42.140/130	1056 332 012	Snap Ring	1	All	
42.180	1056 242 038	Bearing Set	1	All	

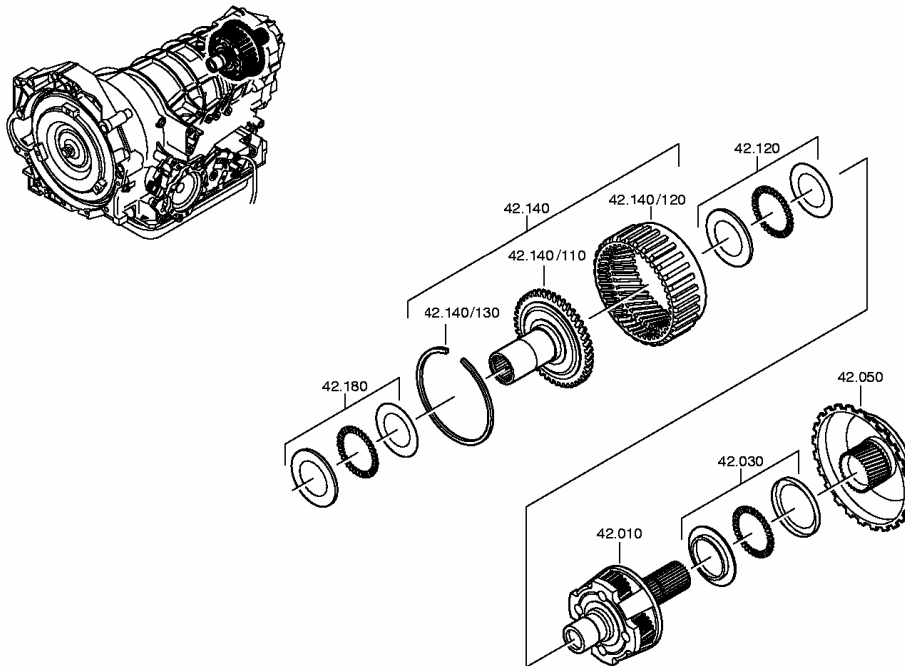

Note: Parts marked with * are only available in kits.



5HP19FLA Spare Parts – Front Axle Differential Group

Pos #	ZF Part #	Description	Qty	Where used (1060 040 ___)	Notes
35.010	1060 235 088	Bevel Gear Set	1	013/044/063/100	
	1060 235 103	Bevel Gear Set	1	002/012	
	1060 235 110	Bevel Gear Set	1	035/036/053/065/075/ 087/103	
	1060 235 111	Bevel Gear Set	1	018/030/054/073/101	
	1060 235 117	Bevel Gear Set	1	093	
35.010/120	0735 371 268	Tapered Roller Bearing	1	All	
35.010/150	0735 370 374	Tapered Roller Bearing	1	All	
35.020	0735 371 895	Tapered Roller Bearing	1	All	
35.030	1056 335 009	Nut	1	All	
35.040	See Page 46	Pinion Bearing Shim	1	All	Selective Shim
35.050	1050 335 016	Retaining Ring	1	All	
35.070	0750 111 399	Double Seal	1	All	* Available in kit 1060 298 031
35.080	See Page 47	Diff. Bearing Shim	1	All	Selective Shim
35.120	See Page 48	Diff. Cover Shim	1	All	Selective Shim
35.146	0734 313 155	O-Ring	1	All	* Available in kit 1060 298 031
35.150	1060 235 081	Cover	1	All	
35.150/110	1060 335 079	Differential Cover	1	All	
35.150/120	0734 310 342	Shaft Seal	1	All	* Available in kit 1060 298 031
35.150/130	1056 335 069	Oil Baffle Plate	1	All	
35.150/140	1043 301 036	Magnet	1	All	

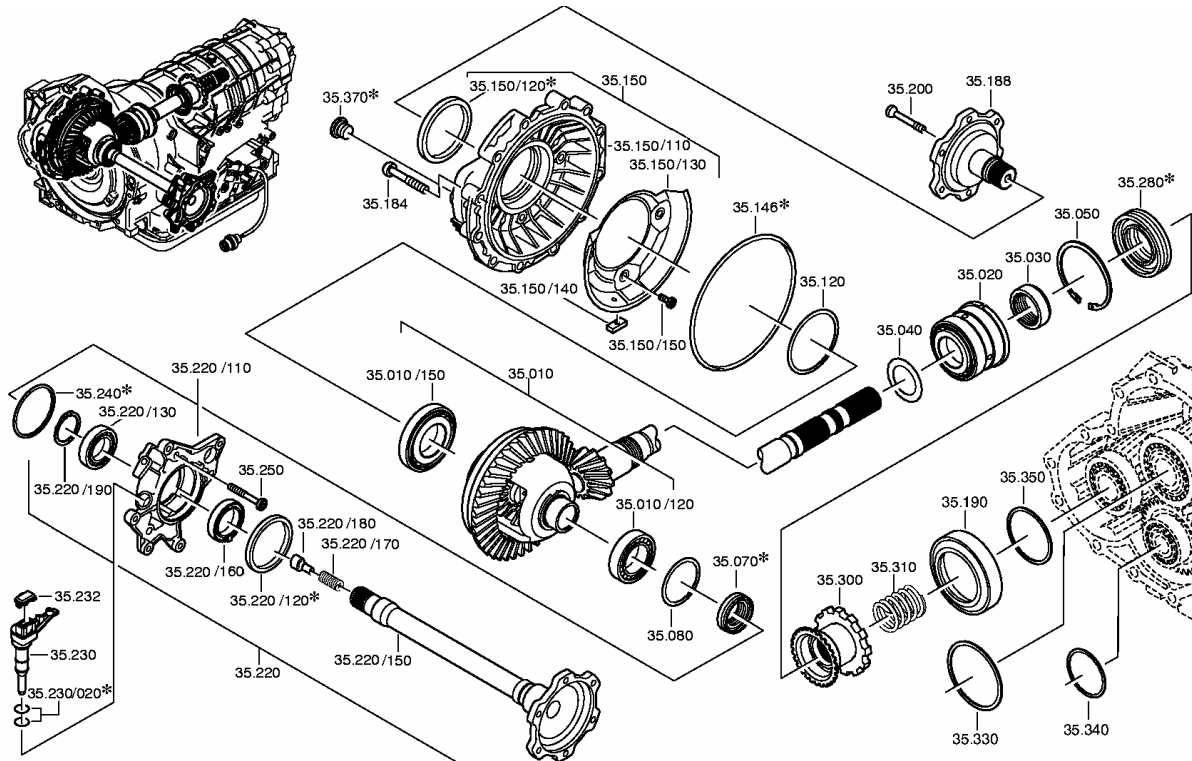

Note: Parts marked with * are only available in kits.



5HP19FLA Spare Parts – Front Axle Differential Group (continued)

Pos #	ZF Part #	Description	Qty	Where used (1060 040 ___)	Notes
35.150/150	0736 101 241	Torx Screw M6x14	3	All	
35.184	0736 617 061	Torx Screw M8x45	12	All	
35.188	1060 235 040	Output Flange	1	018/030/054	
	1060 235 120	Output Flange	1	073/101	
	1060 335 017	Output Flange	1	002/012/013/035/036/ 044/063/065/075/100	
	1060 335 098	Output Flange	1	053/087/093/103	
35.190	1056 337 033	Bearing Ring	1	All	
35.200	0736 029 089	Anti-Fatigue Bolt M8	1	All	
35.220	1060 235 003	Flange Shaft	1	018/030/054	
	1060 235 004	Flange Shaft	1	002/012/013/035/036/ 044/063/065/075/100	
	1060 235 116	Flange Shaft	1	053/087	
	1060 235 119	Flange Shaft	1	073/093/101	
	1060 235 141	Flange Shaft	1	103	
35.220/110	1056 335 053	Speedo Cover	1	All (except 101/103)	
	1060 335 126	Speedo Cover	1	101/103	
35.220/120	0734 319 419	Shaft Seal	1	All	* Available in kit 1060 298 031
35.220/130	0635 331 218	Ball Bearing	1	All	
35.220/150	1060 335 021	Flange Shaft	1	002/012/013/018/030/ 035/036/044/054/063/ 065/075/100	
	1060 335 103	Flange Shaft	1	053/073/087/093/101/ 103	

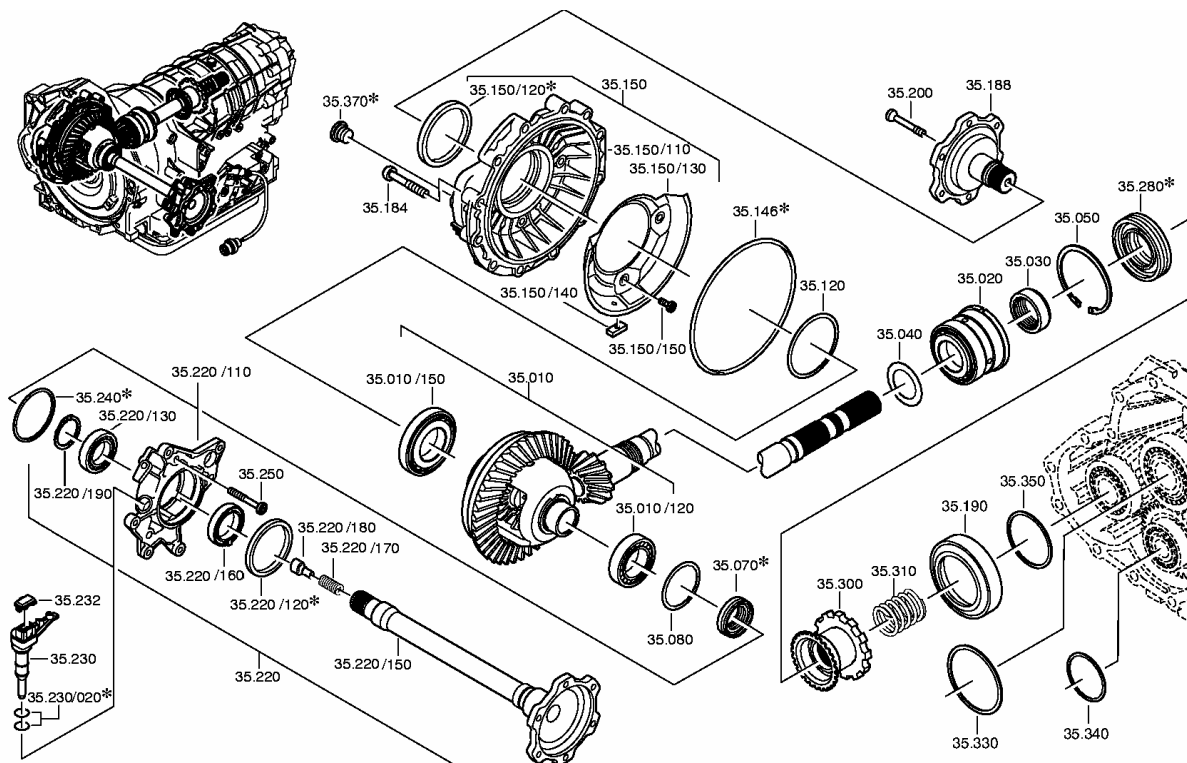

Note: Parts marked with * are only available in kits.



5HP19FLA Spare Parts – Front Axle Differential Group (continued)

Pos #	ZF Part #	Description	Qty	Where used (1060 040 ___)	Notes
35.220/160	0501 315 012	Magnetic Ring	1	002/012/013/018/030/ 035/036/044/054/063/ 065/075/093/100	
35.220/170	0501 308 523	Compression Spring	1	018/030/054/073/093/ 101	
35.220/180	0501 308 528	Tappet	1	018/030/054/073/093/ 101	
35.220/190	0630 501 028	Retaining Ring	1	All	
35.230	0501 208 543	Speed Sensor	1	All	
35.230/020	0501 313 484	O-Ring	2	All	* Available in kit 1060 298 031
35.232	0501 317 696	Cap	1	All	
35.240	0734 317 262	Sealing Ring	1	All	* Available in kit 1060 298 031
35.250	0736 617 061	Torx Screw M8x45	3	All	
35.280	0734 319 529	Shaft Seal	1	All	* Available in kit 1060 298 031
35.300	1060 224 003	Parking Lock Wheel	1	All	
35.310	0732 042 565	Compression Spring	1	All	
35.330	See Page 49	Idle Gear Shim	1	All	Selective Shim
35.340	See Page 50	Output Shaft Gear Shim	1	All	Selective Shim
35.350	See Page 49	Pinion Gear Shim	1	All	Selective Shim
35.370	0636 308 025	Screw Plug M18x1.5	1	All	* Available in kit 1060 298 031

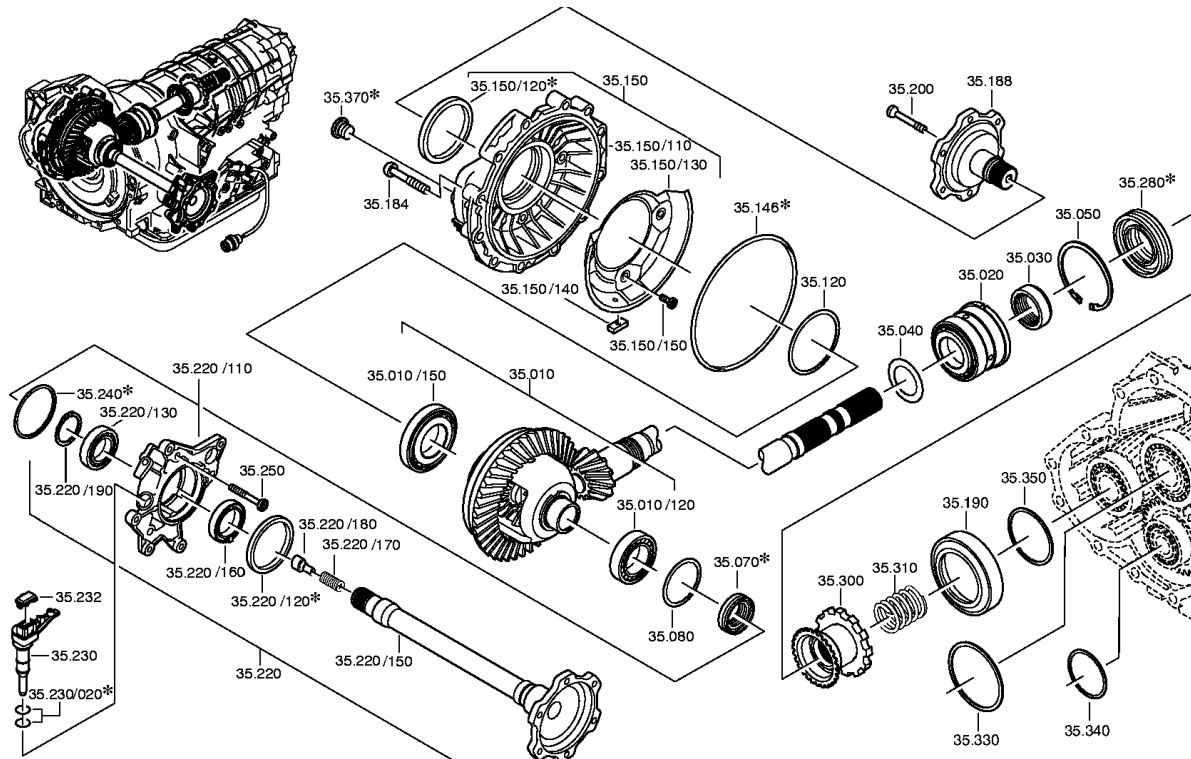

Note: Parts marked with * are only available in kits.



5HP19FLA Spare Parts – Rear Axle Output Group

Pos #	ZF Part #	Description	Qty	Where used (1060 040 ___)	Notes
36.010	1058 336 206	Transfer Case Housing	1	All	
36.030	0735 298 075	Needle Sleeve	1	All	
36.040	0630 513 130	Snap Ring	1	All	
36.060	1058 236 011	Rear Axle Shaft	1	018/030/035/036/044/ 053/054/063/065/073/ 075/087/100/101/103	
	1058 236 013	Rear Axle Shaft	1	012/013/093	
	1058 236 014	Rear Axle Shaft	1	002	
36.060/130	0735 330 452	Ball Bearing	1	All	
36.060/140	0630 503 014	Snap Ring	1	All	
36.060/150	0630 501 038	Retaining Ring	1	All	
36.100	1058 336 003	Washer	1	All	
36.110	1058 336 004	Baffle Plate	1	All	
36.120	0736 100 051	Torx Screw M6x25	5	All	
36.130	0735 298 206	Needle Sleeve	1	All	
36.150	0630 513 037	Snap Ring	1	All	
36.180	1060 236 034	Output Gear	1	002	
	1060 236 035	Output Gear	1	018/030/035/036/044/ 053/054/063/065/073/ 075/087/100/101/103	
	1060 236 036	Output Gear	1	012/093	
	1060 236 039	Output Gear	1	013	

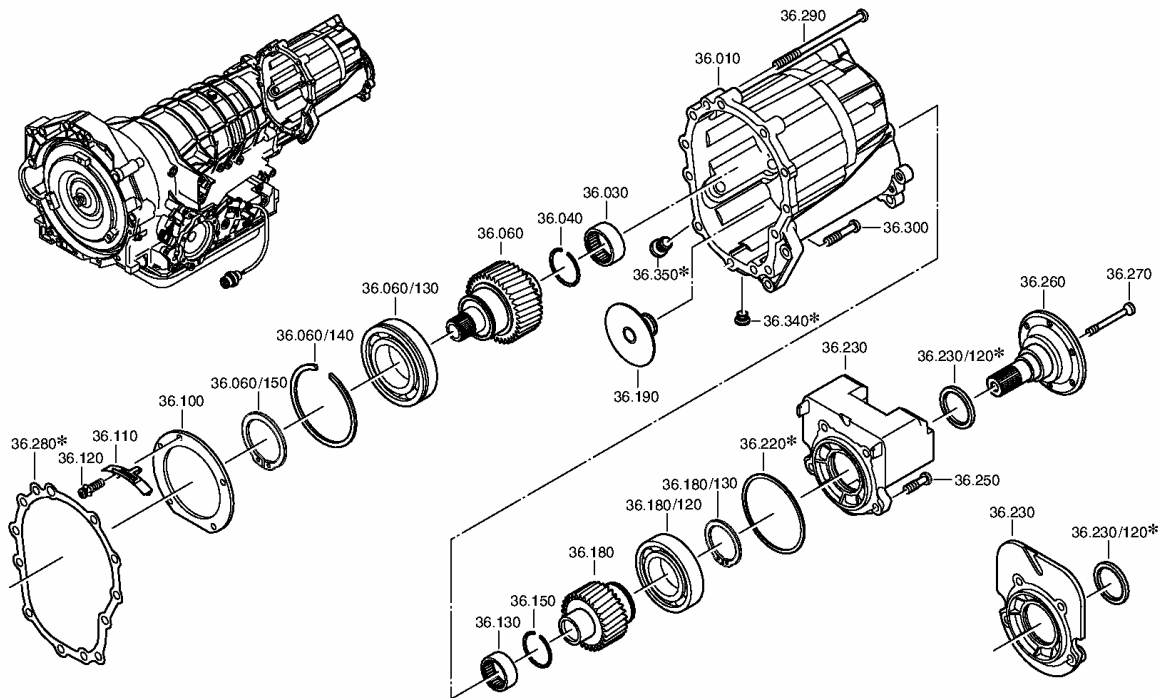

Note: Parts marked with * are only available in kits.



5HP19FLA Spare Parts – Rear Axle Output Group (continued)

Pos #	ZF Part #	Description	Qty	Where used (1060 040 ___)	Notes
36.180/120	0735 330 435	Ball Bearing	1	All	
36.180/130	0630 531 065	Retaining Ring	1	All	
36.190	1058 236 006	Nut	1	All	
36.220	0734 307 291	Sealing Ring	1	All	* Available in kit 1060 298 031
36.230	1060 236 033	Cover	1	018/030/044/053/054/ 063/073/093/100/101	
	1060 236 043	Vibration Absorber	1	012/013/035/036/065/ 075/087/103	
	1060 236 044	Vibration Absorber	1	002	
36.230/120	0734 319 588	Shaft Seal	1	All	* Available in kit 1060 298 031
36.250	0736 617 074	Torx Screw M8x30	4	All	
36.260	1058 336 076	Output Flange	1	All	
36.270	0736 029 089	Anti-Fatigue Bolt M8	1	All	
36.280	1058 336 021	Gasket	1	All	* Available in kit 1060 298 031
36.290	0736 617 063	Torx Screw M8x140	8	All	
36.300	0736 617 061	Torx Screw M8x45	3	All	
36.340	0636 308 024	Screw Plug M12x1.5	1	All	* Available in kit 1060 298 031
36.350	0636 308 025	Screw Plug M18x1.5	1	All	* Available in kit 1060 298 031

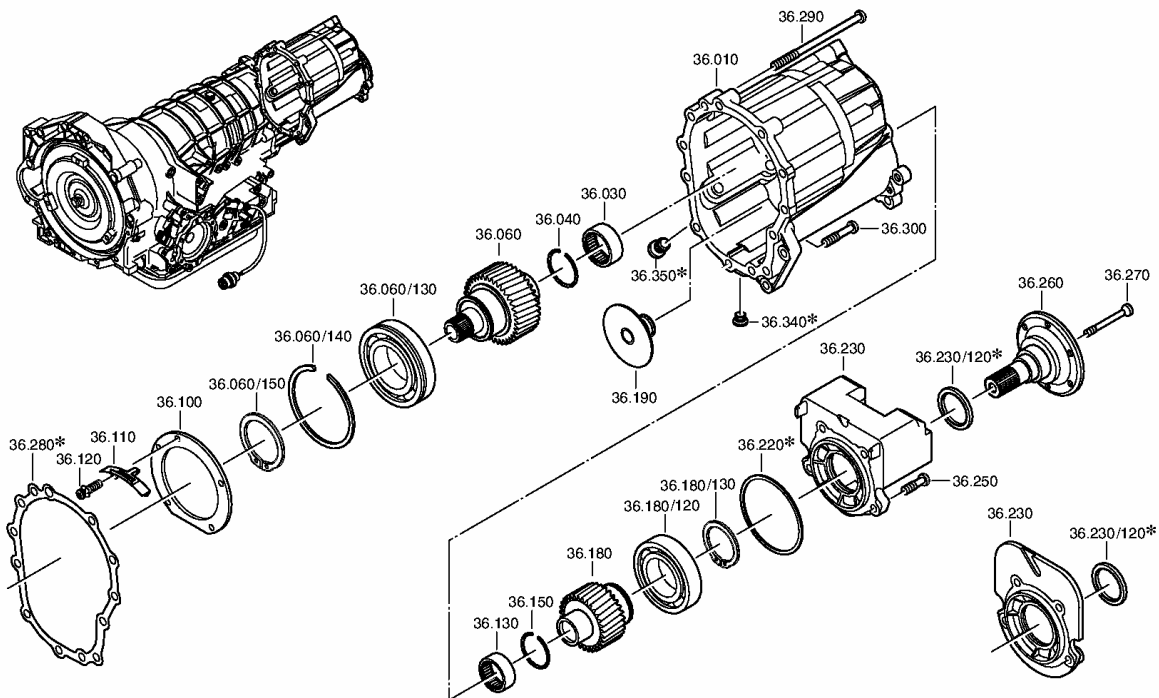

Note: Parts marked with * are only available in kits.



5HP19FLA Spare Parts – Front Axle Output Group

Pos #	ZF Part #	Description	Qty	Where used (1060 040 ___)	Notes
37.010	1056 337 013	Gasket	1	All	* Available in kit 1060 298 031
37.020	0730 062 725	Bush	1	All	
37.030	0735 368 075	Axial Needle Bearing	1	All	
37.040	See Page 50	Output Shim	1	All	Selective Shim
37.060	1056 337 047	Intermediate Housing	1	All (expect 053)	
	1056 337 102	Intermediate Housing	1	053	
37.080	1060 237 012	Front Axle Shaft	1	All (expect 053)	
	1060 237 050	Front Axle Shaft	1	053	
37.080/120	0734 319 604	Shaft Seal	1	All	* Available in kit 1060 298 031
37.080/130	0735 371 321	Tapered Roller Bearing	1	All	
37.080/140	0735 371 489	Tapered Roller Bearing	1	All	
37.130	1060 237 043	Idler Gear	1	All (expect 053)	
	1060 237 051	Idler Gear	1	053	
37.130/120	0735 371 418	Tapered Roller Bearing	1	All	
37.130/130	0735 371 418	Tapered Roller Bearing	1	All	
37.150	1060 237 019	Helical Gear	1	012/018/030/035/036/ 044/054/063/065/073/ 075/087/100/101/103	
	1060 237 021	Helical Gear	1	002/013/093	
	1060 237 052	Helical Gear	1	053	
37.150/120	0735 371 489	Tapered Roller Bearing	1	All	
37.150/130	0735 371 489	Tapered Roller Bearing	1	All	
37.220	0736 617 061	Torx Screw M8x45	6	All	
37.240	0734 319 547	Double Seal	1	All	* Available in kit 1060 298 031
37.280	1043 301 036	Magnet	1	All	
37.310	0631 306 071	Cylindrical Pin	2	All	
37.620	0501 318 900	Breather Tube	1	All	
37.640	0501 314 809	Breather Cover	1	All	

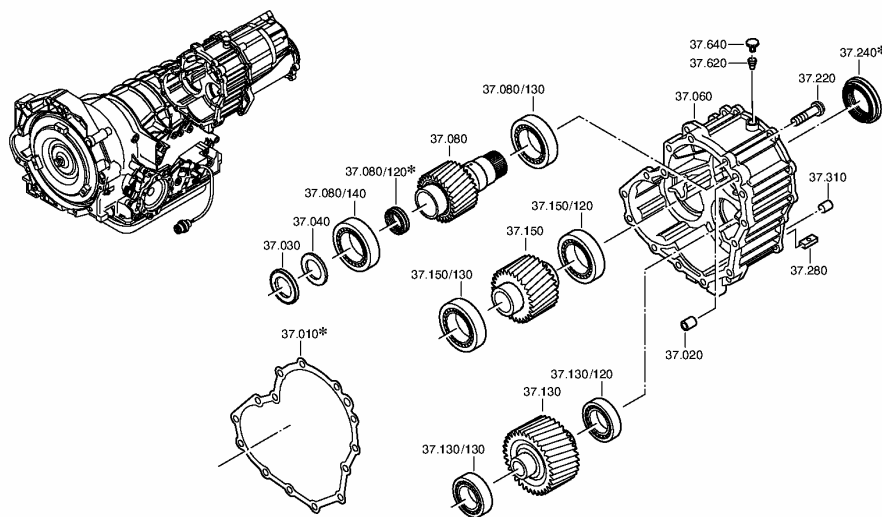

Note: Parts marked with * are only available in kits.



5HP19FLA Spare Parts – Internal Differential Lock Group

Pos #	ZF Part #	Description	Qty	Where used (1060 040 ___)	Notes
38.010	0501 211 936	Differential	1	All	

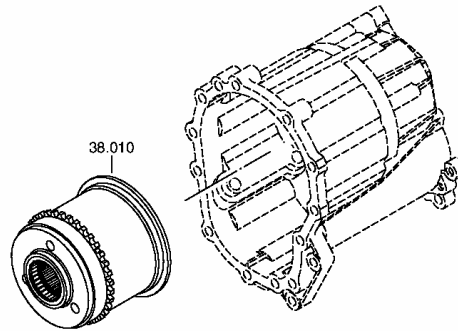
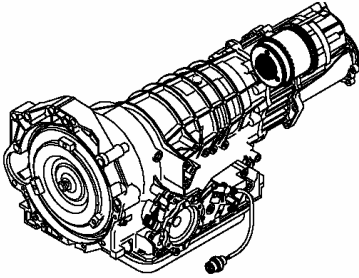

Note: Parts marked with * are only available in kits.



5HP19FLA Spare Parts – Clutch Pack Groups

Pos #	ZF Part #	Description	Qty	Where used (1060 040 ___)	Notes
70.010	1060 270 075	Cylinder A	1	002/012/013/036	
	1060 270 076	Cylinder A	1	018	
	1060 270 082	Cylinder A	1	035/044/053/063/065/ 075/087/093/100/103	
	1060 270 083	Cylinder A	1	030/054/073/101	
70.010/110	1056 370 047	Cylinder A	1	002/012/013/036	
	1056 370 048	Cylinder A	1	018	
	1060 370 060	Cylinder A	1	035/044/053/063/065/ 075/087/093/100/103	
	1060 370 061	Cylinder A	1	030/054/073/101	
70.010/120	0734 313 014	O-Ring	1	All	* Available in kit 1060 298 031
70.010/130	0734 313 029	O-Ring	1	All	* Available in kit 1060 298 031
70.010/140	0501 315 926	Cup Spring	1	All	
70.010/170	1056 370 034	Stop-Ring	1	All	
70.010/180	1056 370 050	Piston	1	All	
70.010/190	1050 302 012	Spring Clutch Disc	1	030/035/044/053/054/ 063/065/073/075/087/ 093/100/101/103	
	1056 370 009	Spring Clutch Disc	1	002/012/013/018/036	
70.010/200	1060 370 002	Steel Plate A	4	018/030/054/073/101	* Available in kit 1060 298 025 * Available in kit 1060 298 026
	1060 370 002	Steel Plate A	5	002/012/013/035/036/ 044/053/063/065/075/ 087/093/100/103	* Available in kit 1060 298 025 * Available in kit 1060 298 026
70.010/210	1050 202 002	Friction Plate A	4	018	* Available in kit 1060 298 024
	1050 202 002	Friction Plate A	5	002/012/013/036	* Available in kit 1060 298 024
	1060 270 039	Friction Plate A	4	030/054/073/101	* Available in kit 1060 298 022
	1060 270 039	Friction Plate A	5	035/044/053/063/065/ 075/087/093/100/103	* Available in kit 1060 298 022
70.010/220	1060 370 003	End Plate A	1	All	* Available in kit 1060 298 025 * Available in kit 1060 298 026
70.010/230	See Page 51	Clutch A Snap Ring	1	All	Selective Snap Ring
70.020	0734 313 163	O-Ring	1	All	* Available in kit 1060 298 031

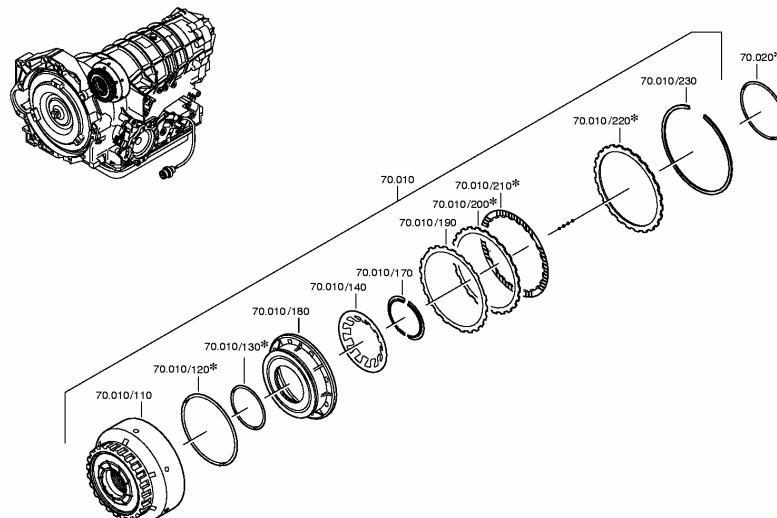

Note: Parts marked with * are only available in kits.



5HP19FLA Spare Parts – Clutch Pack Groups (continued)

Pos #	ZF Part #	Description	Qty	Where used (1060 040 ___)	Notes
71.010	1060 271 007	Input Shaft	1	All	
71.020	0734 317 256	Piston Ring	1	All	* Available in kit 1060 298 031
71.030	0734 317 190	Sealing Ring	1	All	* Available in kit 1060 298 031
71.050	1056 371 060	Piston	1	018/030/054/073/101	
	1056 371 061	Piston	1	002/012/013/035/036/ 044/053/063/065/075/ 087/093/100/103	
71.060	0734 313 022	O-Ring	1	All	* Available in kit 1060 298 031
71.070	0734 313 027	O-Ring	1	All	* Available in kit 1060 298 031
71.080	0501 315 427	Cup Spring	1	All	
71.084	1056 371 025	Oil Dam	1	All	
71.086	0734 313 008	O-Ring	1	All	* Available in kit 1060 298 031
71.090	0630 501 030	Retaining Ring	1	All	
71.094	0501 314 765	Spring Clutch Disc	1	All	
71.100	1060 371 002	Steel Plate E	4	018/030/054/073/101	* Available in kit 1060 298 025 * Available in kit 1060 298 026
	1060 371 002	Steel Plate E	5	002/012/013/035/036/ 044/053/063/065/075/ 087/093/100/103	* Available in kit 1060 298 025 * Available in kit 1060 298 026
71.110	1050 230 032	Friction Plate E	4	018	* Available in kit 1060 298 024
	1050 230 032	Friction Plate E	5	002/012/013/036	* Available in kit 1060 298 024
	1060 271 008	Friction Plate E	4	030/054/073/101	* Available in kit 1060 298 022
	1060 271 008	Friction Plate E	5	035/044/053/063/065/ 075/087/093/100/103	* Available in kit 1060 298 022
71.120	1060 371 003	End Plate E	1	All	* Available in kit 1060 298 025 * Available in kit 1060 298 026
71.130	See Page 51	Clutch E Snap Ring	1	All	Selective Snap Ring
71.150	0734 313 160	O-Ring	1	All	* Available in kit 1060 298 031
71.160	0734 313 211	O-Ring	1	All	* Available in kit 1060 298 031
71.170	1056 370 051	Ring	1	All	
71.180	0730 501 482	Retaining Ring	1	All	
71.200	0735 368 038	Axial Needle Bearing	1	All	

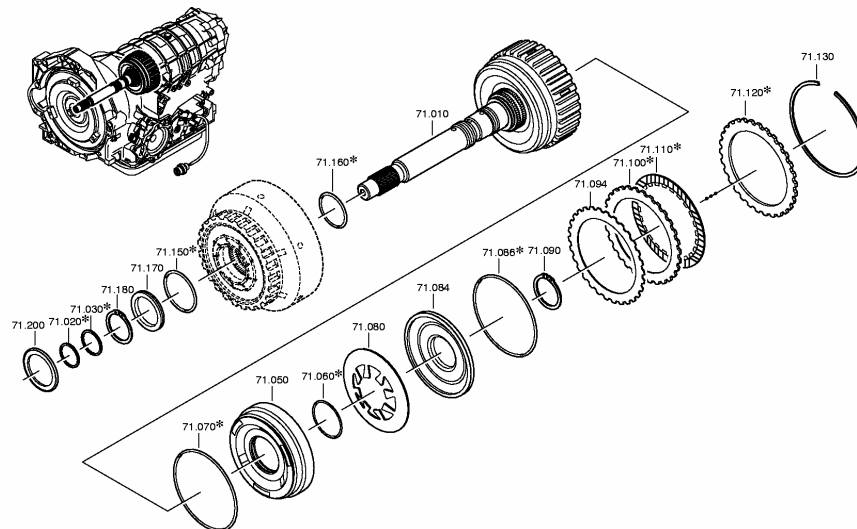

Note: Parts marked with * are only available in kits.



5HP19FLA Spare Parts – Clutch Pack Groups (continued)

Pos #	ZF Part #	Description	Qty	Where used (1060 040 ____)	Notes
72.010	1056 272 051	Cylinder B	1	All	
72.040	1060 272 008	Piston	1	All	
72.050	0734 313 010	O-Ring	1	All	* Available in kit 1060 298 031
72.060	0734 313 007	O-Ring	1	All	* Available in kit 1060 298 031
72.064	0501 315 488	Undulated Spring	1	002/012/013/018/036	
	0501 316 609	Undulated Spring	1	030/035/044/053/054/ 063/065/073/075/087/ 093/100/101/103	
72.070	1060 372 002	Steel Plate B	2	All	* Available in kit 1060 298 025 * Available in kit 1060 298 026
72.080	1060 272 003	Friction Plate B	2	002/012/013/018/036	* Available in kit 1060 298 024
	1060 272 009	Friction Plate B	2	030/035/044/053/054/ 063/065/073/075/087/ 093/100/101/103	* Available in kit 1060 298 022
72.090	1060 372 003	End Plate B	1	All	* Available in kit 1060 298 025 * Available in kit 1060 298 026
72.100	See Page 51	Clutch B Snap Ring	1	All	Selective Snap Ring
72.110	0501 315 493	Cup Spring	1	All	
72.140	1056 310 061	Stop-Ring	1	All	

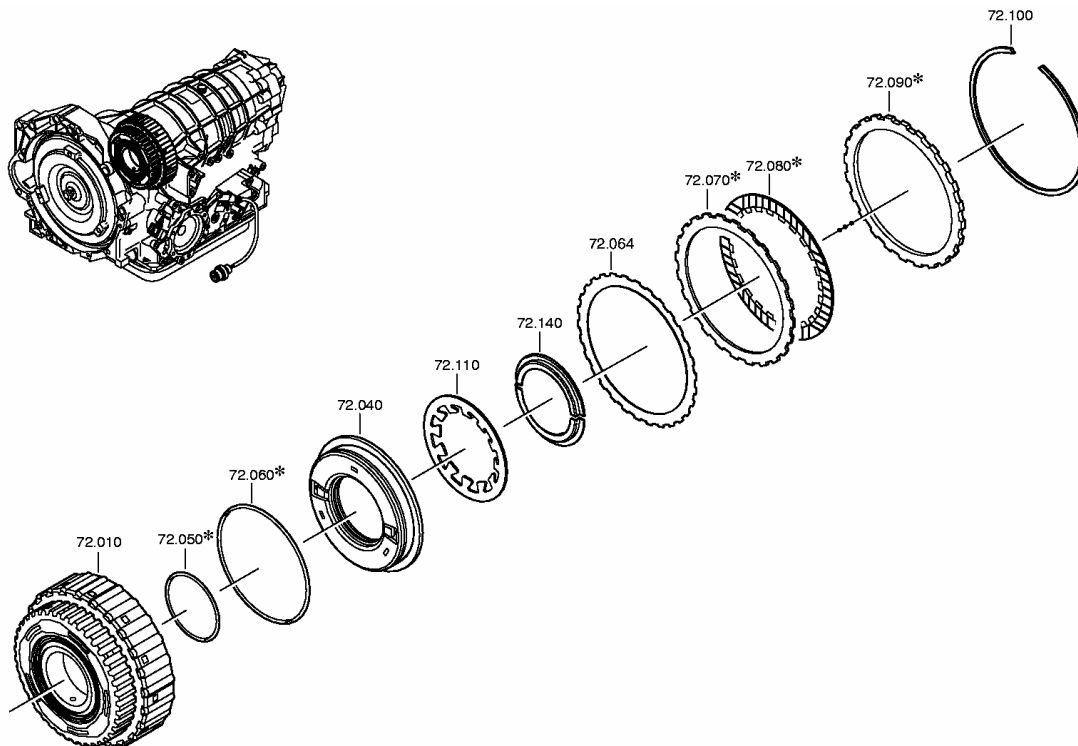

Note: Parts marked with * are only available in kits.



5HP19FLA Spare Parts – Clutch Pack Groups (continued)

Pos #	ZF Part #	Description	Qty	Where used (1060 040 ___)	Notes
73.010	1060 273 018	Cylinder D	1	018	
	1060 273 019	Cylinder D	1	002/012/013/036	
	1060 273 022	Cylinder D	1	030/054/073/101	
	1060 273 032	Cylinder D	1	035/044/053/063/065/ 075/087/093/100/103	
73.010/110	1060 373 002	Cylinder D	1	002/012/013/036	
	1060 373 003	Cylinder D	1	018/030/054/073/101	
	1060 373 014	Cylinder D	1	035/044/053/063/065/ 075/087/093/100/103	
73.010/120	1050 317 050	Piston	1	All	
73.010/130	0734 313 008	O-Ring	1	All	* Available in kit 1060 298 031
73.010/140	0734 313 006	O-Ring	1	All	* Available in kit 1060 298 031
73.010/150	0501 316 285	Cup Spring	1	All	
73.010/160	0501 315 430	Undulated Spring	1	002/012/013/018/036 030/035/044/053/054/ 063/065/073/075/087/ 093/100/101/103	
	1056 373 003	Spring Clutch Disc	1		
73.010/170	1060 370 002	Steel Plate D	5	002/012/013/018/030/ 036/054/073/101	* Available in kit 1060 298 025 * Available in kit 1060 298 026
	1060 370 002	Steel Plate D	6	035/044/053/063/065/ 075/087/093/100/103	* Available in kit 1060 298 025 * Available in kit 1060 298 026
73.010/180	1050 217 002	Friction Plate D	5	002/012/013/018/036	* Available in kit 1060 298 024
	1060 273 023	Friction Plate D	5	030/054/073/101	* Available in kit 1060 298 022
	1060 273 023	Friction Plate D	6	035/044/053/063/065/ 075/087/093/100/103	* Available in kit 1060 298 022
73.010/190	1060 370 003	End Plate D	1	All	* Available in kit 1060 298 025 * Available in kit 1060 298 026
73.010/200	See Page 52	Clutch D Snap Ring	1	All	Selective Snap Ring
73.010/210	0301 317 016	Fitting Key	2	All	
73.020	1060 373 013	Piston	1	All	
73.022	0734 313 021	O-Ring	1	All	* Available in kit 1060 298 031
73.024	0734 313 010	O-Ring	1	All	* Available in kit 1060 298 031

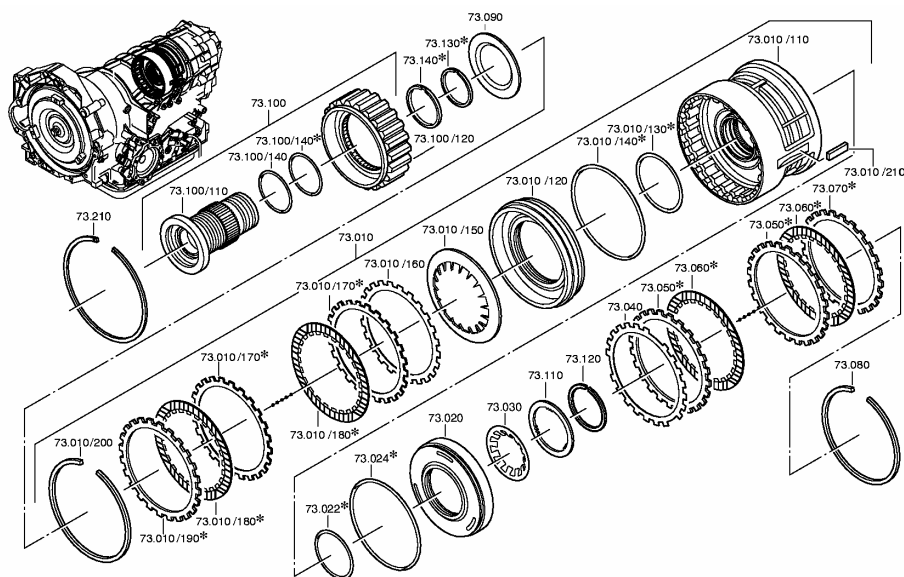

Note: Parts marked with * are only available in kits.



5HP19FLA Spare Parts – Clutch Pack Groups (continued)

Pos #	ZF Part #	Description	Qty	Where used (1060 040 ___)	Notes
73.030	0501 315 932	Cup Spring	1	All	
73.040	0501 315 943	Undulated Spring	1	030/035/044/053/054/ 063/065/073/075/087/ 093/100/101/103	
	1056 377 031	Spring Clutch Disc	1	002/012/013/018/036	
73.050	1060 377 003	Steel Plate G	3	018/030/054/073/101	* Available in kit 1060 298 025 * Available in kit 1060 298 026
	1060 377 003	Steel Plate G	4	002/012/013/035/036/ 044/053/063/065/075/ 087/093/100/103	* Available in kit 1060 298 025 * Available in kit 1060 298 026
73.060	1060 277 031	Friction Plate G	3	030/054/073/101	* Available in kit 1060 298 022
	1060 277 031	Friction Plate G	4	035/044/053/063/065/ 075/087/093/100/103	* Available in kit 1060 298 022
	1056 277 036	Friction Plate G	3	018	* Available in kit 1060 298 024
	1056 277 036	Friction Plate G	4	002/012/013/036	* Available in kit 1060 298 024
73.070	1060 377 004	End Plate G	1	All	* Available in kit 1060 298 025 * Available in kit 1060 298 026
73.080	See Page 52	Clutch G Snap Ring	1	All	Selective Snap Ring
73.090	1056 373 021	Fixing Washer	1	All	
73.100	1060 273 013	Carrier	1	002/012/013/018/036	
	1060 273 035	Carrier	1	030/035/044/053/054/ 063/065/073/075/087/ 093/100/101/103	
73.100/110	1060 273 028	Carrier	1	All	
73.100/120	1056 273 081	Free Wheel	1	002/012/013/018/036	
	1060 273 034	Free Wheel	1	030/035/044/053/054/ 063/065/073/075/087/ 093/100/101/103	
73.100/140	0734 313 086	O-Ring	2	All	* Available in kit 1060 298 031
73.110	1056 376 005	Thrust Washer	1	All	
73.120	0730 513 461	Snap Ring	1	All	
73.130	0734 317 205	Piston Ring	1	All	* Available in kit 1060 298 031
73.140	0734 317 205	Piston Ring	1	All	* Available in kit 1060 298 031
73.210	1056 373 053	Snap Ring	1	All	

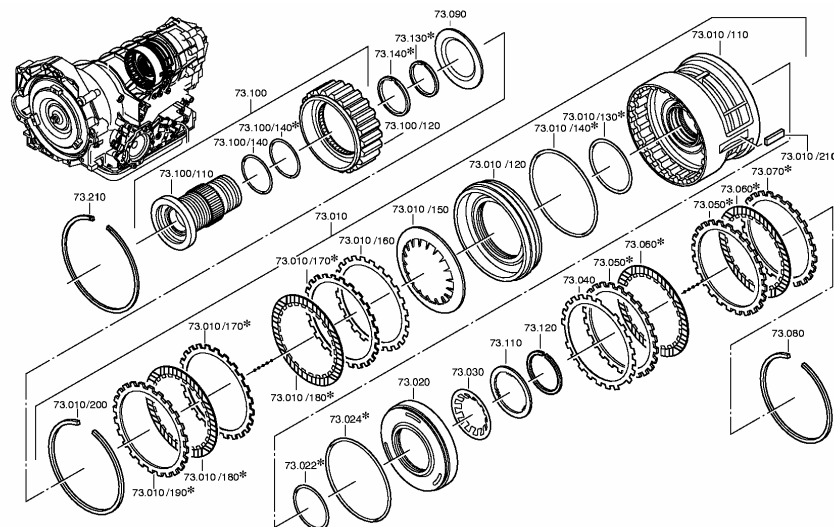

Note: Parts marked with * are only available in kits.



5HP19FLA Spare Parts – Clutch Pack Groups (continued)

Pos #	ZF Part #	Description	Qty	Where used (1060 040 ___)	Notes
77.010	1060 277 026	Cylinder F	1	002/012/013/036	
	1060 277 027	Cylinder F	1	018	
	1060 277 034	Cylinder F	1	030/054/073/101	
	1060 277 035	Cylinder F	1	035/044/053/063/065/ 075/087/093/100/103	
77.010/110	1060 277 010	Cylinder F	1	002/012/013/035/036/ 044/053/063/065/075/ 087/093/100/103	
	1060 277 018	Cylinder F	1	018/030/054/073/101	
77.010/120	1056 377 038	Piston	1	All	
77.010/130	0734 313 008	O-Ring	1	All	* Available in kit 1060 298 031
77.010/140	0734 313 010	O-Ring	1	All	* Available in kit 1060 298 031
77.010/150	1060 377 016	Pressure Plate	1	All	
77.010/160	0501 315 931	Cup Spring	1	All	
77.010/170	1060 377 009	Stop-Ring	1	All	
77.010/180	0501 315 943	Spring Clutch Disc	1	030/035/044/053/054/ 063/065/073/075/087/ 093/100/101/103	
	1056 377 031	Spring Clutch Disc	1	002/012/013/018/036	
77.010/190	1060 377 002	Steel Plate F	5	018/030/054/073/101	* Available in kit 1060 298 025 * Available in kit 1060 298 026
	1060 377 002	Steel Plate F	6	002/012/013/035/036/ 044/053/063/065/075/ 087/093/100/103	* Available in kit 1060 298 025 * Available in kit 1060 298 026
77.010/200	1056 277 036	Friction Plate	4	018	* Available in kit 1060 298 024
	1056 277 036	Friction Plate F	5	002/012/013/036	* Available in kit 1060 298 024
	1060 277 031	Friction Plate F	4	030/054/073/101	* Available in kit 1060 298 022
	1060 277 031	Friction Plate F	5	035/044/053/063/065/ 075/087/093/100/103	* Available in kit 1060 298 022
77.010/210	See Page 52	Clutch F Snap Ring	1	All	Selective Snap Ring

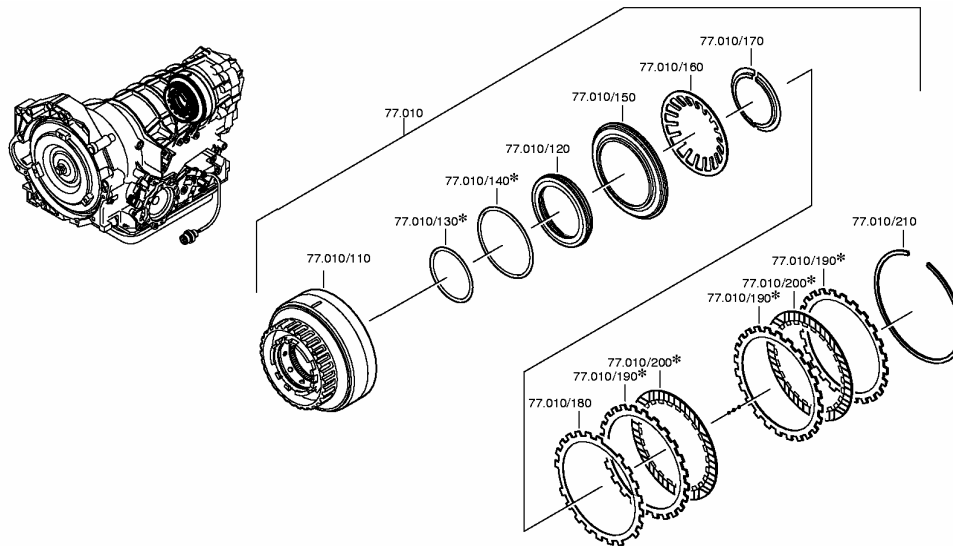

Note: Parts marked with * are only available in kits.



5HP19FLA Valve Body – Duct Plate Group

Pos #	ZF Part #	Description	Qty	Where used (1060 040 ___)	Notes
27.010	1060 327 140	Duct Plate	1	002/012/013/018/036	
	1060 327 141	Duct Plate	1	030/035/044/053/054/ 063/065/073/075/087/ 093/100/101/103	
27.020	0501 210 474	Speed Sensor (Hall Effect)	1	030/035/044/053/054/ 063/065/073/075/087/ 093/100/101/103	
	0501 311 086	Speed Sensor	1	002/012/013/018/036	
27.030	0736 101 233	Torx Screw M6x15	1	030/035/044/053/054/ 063/065/073/075/087/ 093/100/101/103	
	0736 101 352	Torx Screw M5x40	2	002/012/013/018/036	
27.050	1056 327 144	Spacer Ring	2	002/012/013/018/036	
27.070	0501 313 177	Screen	1	All	
27.090	1060 227 019	Valve	1	All	
27.094	1060 227 020	Valve	1	002/012/013/018/036	
27.100	1043 326 037	Ball	2	002/012/013/018/036	
	1043 326 037	Ball	3	030/035/044/053/054/ 063/065/073/075/087/ 093/100/101/103	
27.110	1056 327 045	Valve Orifice D=1.9	1	002/012/013/018/036	
	1056 327 077	Valve Orifice D=2.5	1	030/035/044/053/054/ 063/065/073/075/087/ 093/100/101/103	
27.114	1056 327 039	Valve Orifice D=1.7	1	030/035/044/053/054/ 063/065/073/075/087/ 093/100/101/103	
27.120	1056 327 039	Valve Orifice D=1.7	1	All	
27.124	1056 327 018	Valve Orifice D=0.8	1	030/035/044/053/054/ 063/065/073/075/087/ 093/100/101/103	
27.130	1056 327 020	Valve Orifice D=1.2	1	All	
27.134	1056 327 045	Valve Orifice D=1.9	1	030/035/044/053/054/ 063/065/073/075/087/ 093/100/101/103	
	1056 327 077	Valve Orifice D=2.5	1	002/012/013/018/036	
27.140	1056 327 019	Valve Orifice D=1.0	1	002/012/013/018/036	
	1056 327 020	Valve Orifice D=1.2	1	030/035/044/053/054/ 063/065/073/075/087/ 093/100/101/103	
27.144	1056 327 077	Valve Orifice D=2.5	1	All	
27.150	1056 327 019	Valve Orifice D=1.0	1	All	
27.154	1056 327 040	Valve Orifice (solid)	1	002/012/013/018/036	
27.156	1060 327 020	Valve Orifice D=0.6	1	002/012/013/018/036	
27.160	1056 327 020	Valve Orifice D=1.2	1	002/012/013/018/036	
27.164	1056 327 020	Valve Orifice D=1.2	1	030/035/044/053/054/ 063/065/073/075/087/ 093/100/101/103	
27.170	1056 327 039	Valve Orifice D=1.7	1	002/012/013/018/036	
	1056 327 094	Valve Orifice D=1.4	1	030/035/044/053/054/ 063/065/073/075/087/ 093/100/101/103	
27.174	1056 327 040	Valve Orifice (solid)	1	030/035/044/053/054/ 063/065/073/075/087/ 093/100/101/103	
27.180	1019 327 063	Valve Orifice D=1.0	1	All	

Note: Parts marked with * are only available in kits.



5HP19FLA Valve Body – Duct Plate Group (continued)

Pos #	ZF Part #	Description	Qty	Where used (1060 040 ____)	Notes
27.188	0501 314 645	Rubber Part	1	All	* Available in kit 1060 298 031
	1068 227 039	Piston	1	All	* Available in kit 1060 298 031
27.190	1019 327 063	Valve Orifice D=1.0	1	All	
27.194	1056 327 020	Valve Orifice D=1.2	1	030/035/044/053/054/ 063/065/073/075/087/ 093/100/101/103	
27.198	0501 314 645	Rubber Part	1	All	* Available in kit 1060 298 031
	1068 227 039	Piston	1	All	* Available in kit 1060 298 031
27.200	1019 327 063	Valve Orifice D=1.0	1	All	
27.208	0501 314 645	Rubber Part	1	All	* Available in kit 1060 298 031
	1068 227 039	Piston	1	All	* Available in kit 1060 298 031
27.210	1019 327 063	Valve Orifice D=1.0	1	All	
27.220	1060 327 069	Gasket	1	002/012/013/018/036	* Available in kit 1060 298 031
	1060 327 090	Gasket	1	030/035/044/053/054/ 063/065/073/075/087/ 093/100/101/103	* Available in kit 1060 298 031
27.230	1060 327 109	Intermediate Sheet	1	002/012/013/018/036	
	1060 327 127	Intermediate Sheet	1	030/035/044/053/054/ 063/065/073/075/087/ 093/100/101/103	
27.250	0736 101 354	Torx Screw M5x60	4	All	
27.260	0736 101 354	Torx Screw M5x60	7	All	
27.270	0736 101 352	Torx Screw M5x40	10	All	
27.274	1056 328 002	Fixing Plate	1	All	
27.280	0631 302 165	Cylindrical Pin M6x32	1	All	
27.290	0736 101 350	Torx Screw M6x44	5	All	
27.340	1060 227 022	Wiring Harness	1	030/035/044/053/054/ 063/065/073/075/087/ 093/100/101/103	
	1056 227 046	Wiring Harness	1	002/012/013/018/036	
27.340/116	0501 209 253	O-Ring	2	All	* Available in kit 1060 298 031
27.350	0501 305 955	Cable Terminal	1	All	
27.360	0501 315 055	Clip	1	All	
27.390	1058 327 026	Retaining Clamp	1	All	
27.392	1060 327 005	Mounting Clip	1	093	Not shown in exploded view
27.394	1060 327 006	Mounting Clip	1	093	Not shown in exploded view
27.400	0736 101 176	Torx Screw M6x30	1	002	
	0736 101 349	Torx Screw M6x30	1	012/013/018/036	
27.410	0736 101 069	Torx Screw M6x60	16	002	
	0736 101 348	Torx Screw M6x59	16	All (except 002)	
27.420	0501 209 251	Filter	1	All	* Available in kit 5HP19FKFL
27.420/020	0501 314 578	Sealing Ring	1	All	* Available in kit 1060 298 031 * Available in kit 5HP19FKFL
27.440	0736 101 094	Torx Screw M5x12	2	002	
	0736 101 372	Torx Screw M5x12	2	All (except 002)	
27.540	1060 227 020	Valve	1	030/035/044/053/054/ 063/065/073/075/087/ 093/100/101/103	
27.560	1060 227 020	Valve	1	030/035/044/053/054/ 063/065/073/075/087/ 093/100/101/103	
27.700	0501 318 717	Protecting Cap	1	All	

Note: Parts marked with * are only available in kits.



5HP19FLA Valve Body – Duct Plate Group (continued)

Exploded view of Duct Plate Group for following applications: 1060 040 –002/012/013/018/036

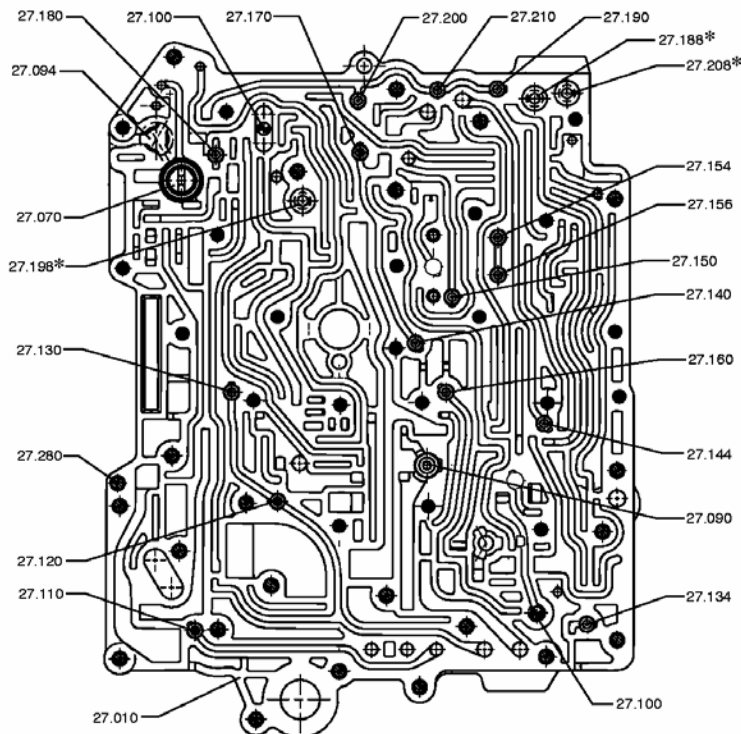
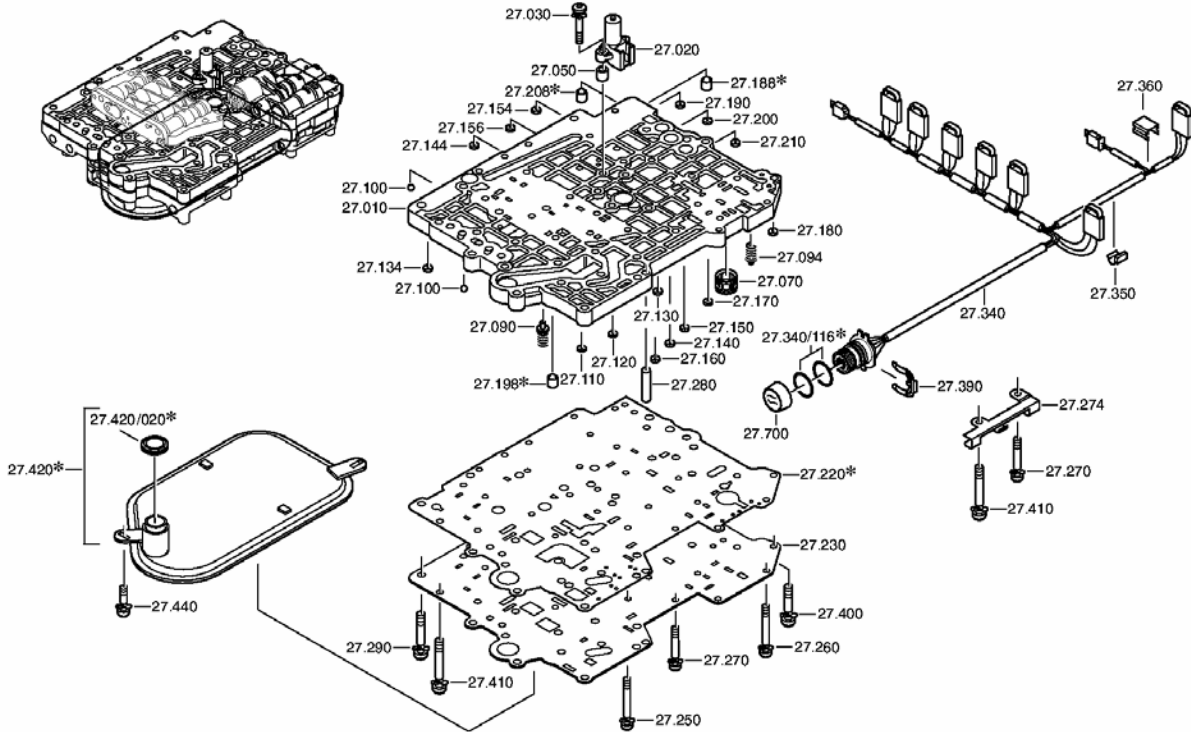

Note: Parts marked with * are only available in kits.



5HP19FLA Valve Body – Duct Plate Group (continued)

Exploded view of Duct Plate Group for following applications: 1060 040 –030/035/044/053/054/063/065/073/075/087/093/100/101/103

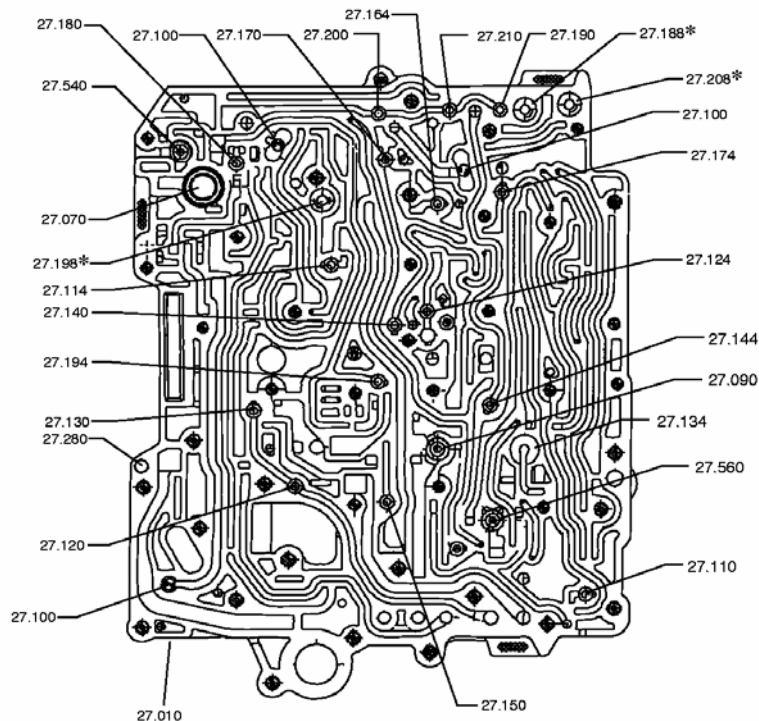
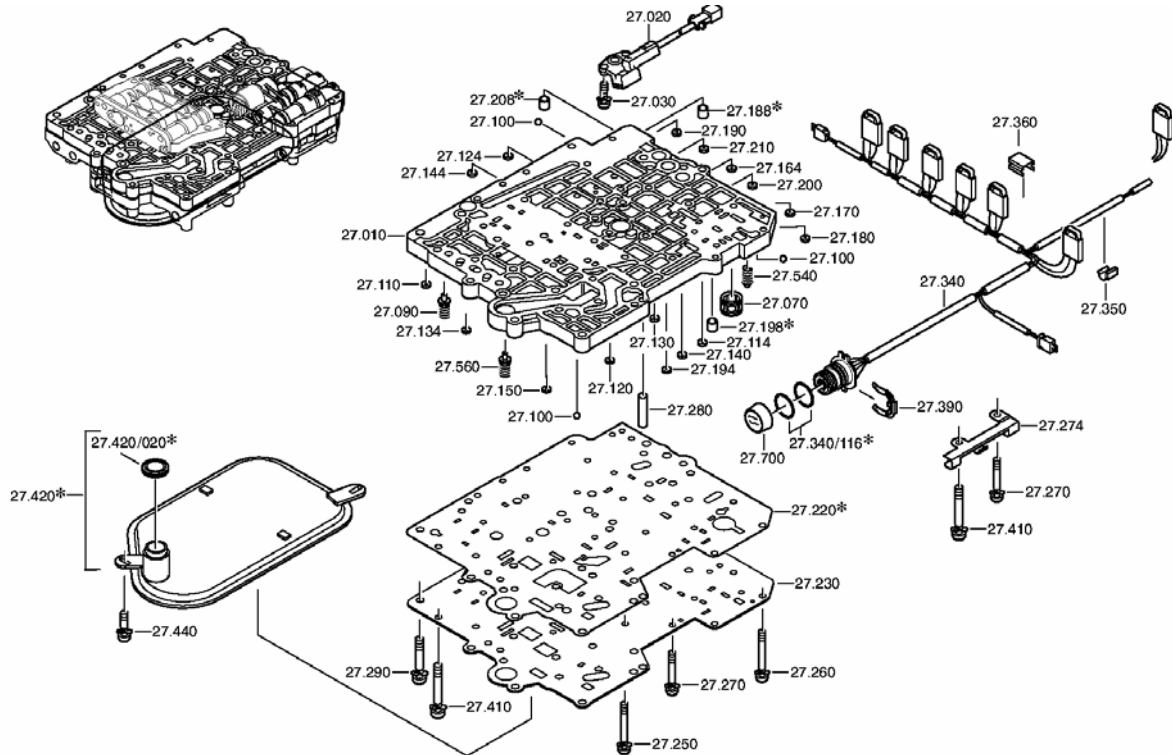

Note: Parts marked with * are only available in kits.



5HP19FLA Valve Body – Valve Housing Groups

Pos #	ZF Part #	Description	Qty	Where used (1060 040 ___)	Notes
50.010	1060 327 134	Valve Housing	1	002/012/013/018/036/ 053/065/073/075/087/ 093/101/103	
	1060 327 138	Valve Housing	1	030/035/044/054/063/ 100	
50.020	1056 327 173	Selector Shift Valve	1	All	
50.030	1056 327 003	Piston	1	All	
50.036	1024 323 202	Spring Cup	1	All	
50.050	0732 041 524	Compression Spring	1	030/035/044/053/054/ 063/065/073/075/087/ 093/100/101/103	
	0732 042 115	Compression Spring	1	002/012/013/018/036	
50.060	1056 327 183	Piston	1	All	
50.070	1056 327 142	Stop Plate	1	All	
50.100	1056 328 001	Piston	1	002/012/013/018/036 030/035/044/053/054/ 063/065/073/075/087/ 093/100/101/103	
	1060 327 096	Piston	1		
50.130	0732 041 197	Compression Spring	1	030/035/044/053/054/ 063/065/073/075/087/ 093/100/101/103	
	0732 042 519	Compression Spring	1	002/012/013/018/036	
50.140	1043 226 028	Valve	1	002/012/013/018/036	
50.220	1043 326 169	Valve Spool	1	All	
50.230	0732 041 336	Compression Spring	1	002/012/013/018/036 030/035/044/053/054/ 063/065/073/075/087/ 093/100/101/103	
	0732 041 462	Compression Spring	1		
50.240	1043 326 092	Plug	1	002/012/013/018/036	

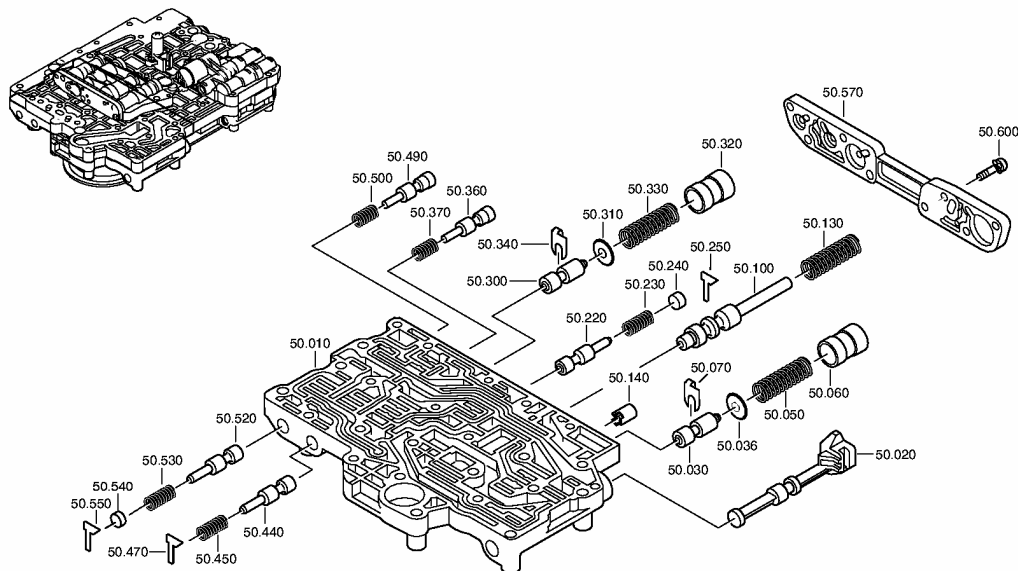

Note: Parts marked with * are only available in kits.



5HP19FLA Valve Body – Valve Housing Groups (continued)

Pos #	ZF Part #	Description	Qty	Where used (1060 040 ___)	Notes
50.250	1068 327 007	Support Plate	1	002/012/013/018/036	
50.300	1056 327 003	Piston	1	002/012/013/018/036	
50.310	1024 323 202	Spring Cup	1	002/012/013/018/036	
50.320	1056 327 183	Piston	1	002/012/013/018/036	
	1058 327 017	Damper Piston	1	030/035/044/053/054/ 063/065/073/075/087/ 093/100/101/103	
50.330	0732 041 814	Compression Spring	1	002/012/013/018/036	
	0732 042 653	Compression Spring	1	030/035/044/053/054/ 063/065/073/075/087/ 093/100/101/103	
50.340	1056 327 142	Stop Plate	1	002/012/013/018/036	
50.360	1055 327 015	Piston	1	002/012/013/018/036	
	1060 327 059	Piston	1	030/035/044/053/054/ 063/065/073/075/087/ 093/100/101/103	
50.370	0732 041 526	Compression Spring	1	002/012/013/018/036	
	0732 042 567	Compression Spring	1	030/035/044/053/054/ 063/065/073/075/087/ 093/100/101/103	
50.440	1043 326 169	Valve Spool	1	All	
50.450	0732 041 809	Compression Spring	1	002/012/013/018/036	
	0732 042 660	Compression Spring	1	030/035/044/053/054/ 063/065/073/075/087/ 093/100/101/103	
50.470	1068 327 007	Support Plate	1	All	

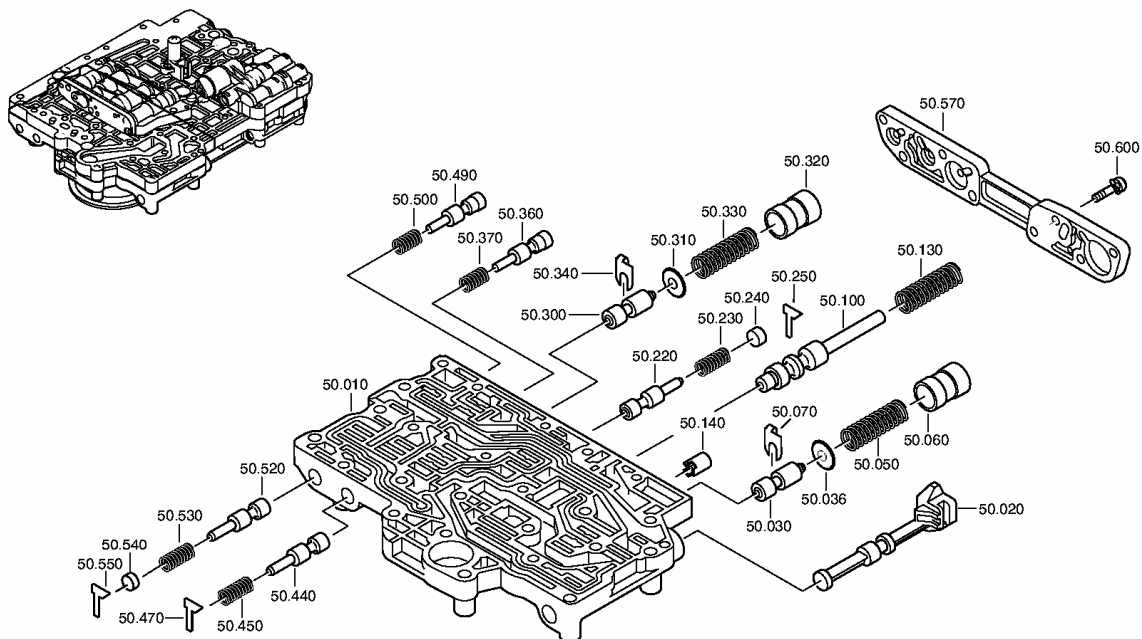

Note: Parts marked with * are only available in kits.



5HP19FLA Valve Body – Valve Housing Groups (continued)

Pos #	ZF Part #	Description	Qty	Where used (1060 040 ___)	Notes
50.490	1055 327 015	Piston	1	002/012/013/018/036	
	1060 327 105	Piston	1	030/035/044/053/054/ 063/065/073/075/087/ 093/100/101/103	
50.500	0732 041 526	Compression Spring	1	002/012/013/018/036	
	0732 041 527	Compression Spring	1	030/035/044/053/054/ 063/065/073/075/087/ 093/100/101/103	
50.520	1043 326 169	Valve Spool	1	All	
50.530	0732 041 809	Compression Spring	1	002/012/013/018/036	
	0732 042 660	Compression Spring	1	030/035/044/053/054/ 063/065/073/075/087/ 093/100/101/103	
50.540	1055 327 101	Sealing Cap	1	030/035/044/053/054/ 063/065/073/075/087/ 093/100/101/103	
50.550	1068 327 007	Support Plate	1	All	
50.570	1056 327 128	Cover	1	002/012/013/018/036	
	1060 327 049	Cover	1	030/035/044/053/054/ 063/065/073/075/087/ 093/100/101/103	
50.600	0736 101 066	Torx Screw M5x18	8	002/012/013/018/036	
	0736 101 066	Torx Screw M5x18	9	030/035/044/053/054/ 063/065/073/075/087/ 093/100/101/103	

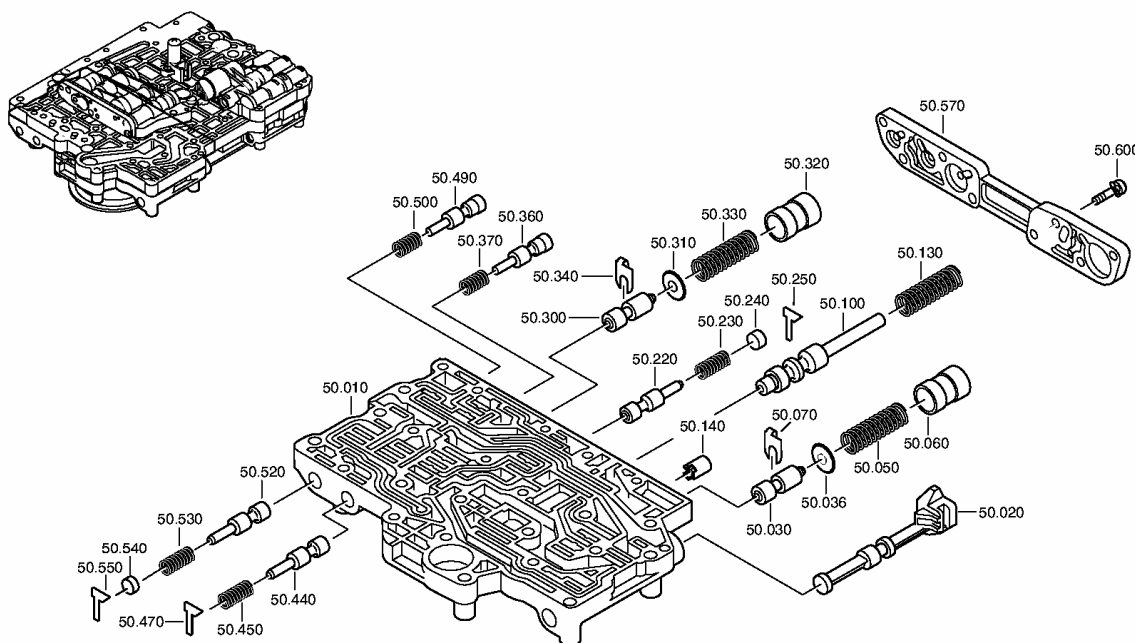

Note: Parts marked with * are only available in kits.



5HP19FLA Valve Body – Valve Housing Groups (continued)

Pos #	ZF Part #	Description	Qty	Where used (1060 040 ___)	Notes
51.010	1060 327 125	Valve Housing	1	030/035/044/053/054/ 063/065/073/075/087/ 093/100/101/103	
	1060 327 135	Valve Housing	1	002/012/013/018/036	
51.030	1043 326 169	Valve Spool	1	All	
51.040	0732 041 820	Compression Spring	1	030/035/044/053/054/ 063/065/073/075/087/ 093/100/101/103	
	0732 041 870	Compression Spring	1	002/012/013/018/036	
51.050	1068 327 007	Support Plate	1	All	
51.080	1056 327 029	Gear Shift Slide	1	All	
51.090	0732 041 462	Compression Spring	1	002/012/013/018/036	
	0732 041 826	Compression Spring	1	030/035/044/053/054/ 063/065/073/075/087/ 093/100/101/103	
51.104	1043 326 307	Plug	1	All	
51.110	1068 327 007	Support Plate	1	All	
51.140	1056 327 028	Piston	1	All	
51.170	0732 041 462	Compression Spring	1	002/012/013/018/036	
	0732 041 826	Compression Spring	1	030/035/044/053/054/ 063/065/073/075/087/ 093/100/101/103	
51.190	1068 327 007	Support Plate	1	All	
51.230	1043 326 169	Valve Spool	1	All	
51.240	0732 041 462	Compression Spring	1	002/012/013/018/036	
	0732 041 826	Compression Spring	1	030/035/044/053/054/ 063/065/073/075/087/ 093/100/101/103	
51.250	1068 327 007	Support Plate	1	All	

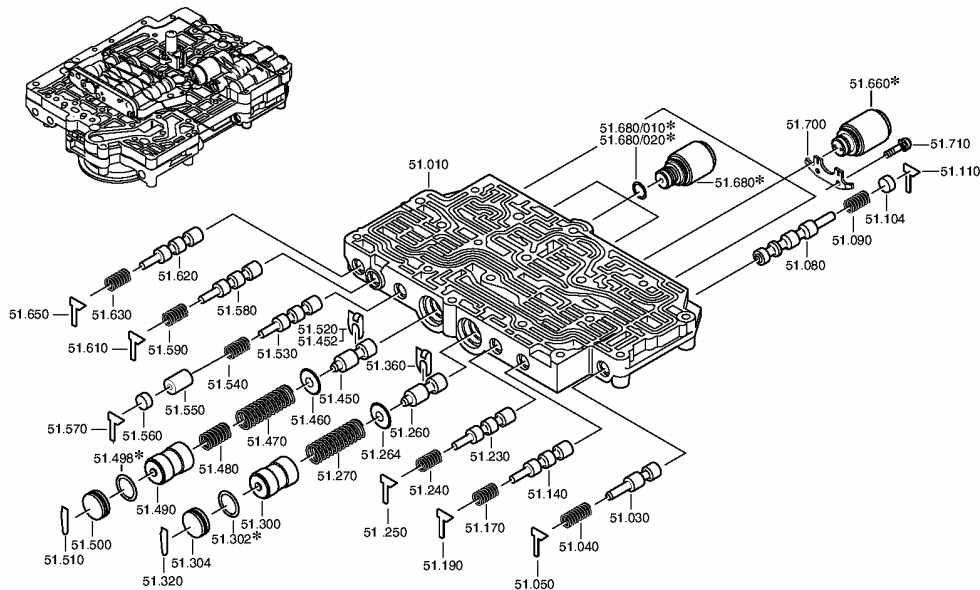

Note: Parts marked with * are only available in kits.



5HP19FLA Valve Body – Valve Housing Groups (continued)

Pos #	ZF Part #	Description	Qty	Where used (1060 040 ___)	Notes
51.260	1056 327 003	Piston	1	All	
51.264	1024 323 202	Spring Cup	1	All	
51.270	0732 041 340	Compression Spring	1	002/012/013/018/036 030/035/044/053/054/ 063/065/073/075/087/ 093/100/101/103	
	0732 042 115	Compression Spring	1	002/012/013/018/036 030/035/044/053/054/ 063/065/073/075/087/ 093/100/101/103	
51.300	1056 327 183	Piston	1	All	
51.302	0734 313 190	O-Ring	1	All	* Available in kit 1060 298 031
51.304	1060 327 068	Plug	1	All	
51.320	1060 327 119	Locking Wire	1	All	
51.360	1056 327 142	Stop Plate	1	All	
51.450	1056 327 003	Piston	1	002/012/013/018/036 030/035/044/053/054/ 063/065/073/075/087/ 093/100/101/103	
	1056 327 116	Piston	1	030/035/044/053/054/ 063/065/073/075/087/ 093/100/101/103	
51.452	1056 327 142	Stop Plate	1	030/035/044/053/054/ 063/065/073/075/087/ 093/100/101/103	
51.460	1024 323 202	Spring Cup	1	002/012/013/018/036	
51.470	0732 041 968	Compression Spring	1	030/035/044/053/054/ 063/065/073/075/087/ 093/100/101/103	
	0732 042 627	Compression Spring	1	002/012/013/018/036	
51.480	0732 042 771	Compression Spring	1	002/012/013/018/036	
51.490	1056 327 183	Piston	1	002/012/013/018/036 030/035/044/053/054/ 063/065/073/075/087/ 093/100/101/103	
	1058 327 017	Damper Piston	1	030/035/044/053/054/ 063/065/073/075/087/ 093/100/101/103	

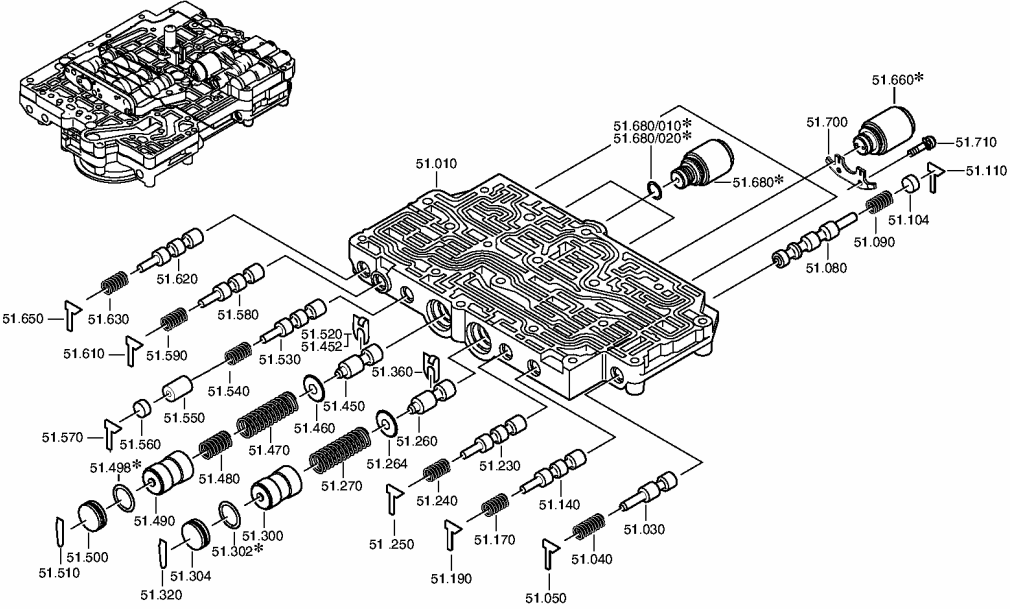

Note: Parts marked with * are only available in kits.



5HP19FLA Valve Body – Valve Housing Groups (continued)

Pos #	ZF Part #	Description	Qty	Where used (1060 040 __)	Notes
51.498	0734 313 190	O-Ring	1	All	* Available in kit 1060 298 031
51.500	1060 327 068	Plug	1	All	
51.510	1060 327 119	Locking Wire	1	All	
51.520	1056 327 142	Stop Plate	1	002/012/013/018/036	
51.530	1056 327 028	Piston	1	002/012/013/018/036	
	1060 327 106	Piston	1	030/035/044/053/054/ 063/065/073/075/087/ 093/100/101/103	
51.540	0732 041 462	Compression Spring	1	002/012/013/018/036	
	0732 041 755	Compression Spring	1	030/035/044/053/054/ 063/065/073/075/087/ 093/100/101/103	
51.550	1060 327 107	Piston	1	030/035/044/053/054/ 063/065/073/075/087/ 093/100/101/103	
51.560	1043 326 307	Plug	1	All	
51.570	1068 327 007	Support Plate	1	All	
51.580	1043 326 169	Valve Spool	1	All	
51.590	0732 041 337	Compression Spring	1	030/035/044/053/054/ 063/065/073/075/087/ 093/100/101/103	
	0732 041 526	Compression Spring	1	002/012/013/018/036	

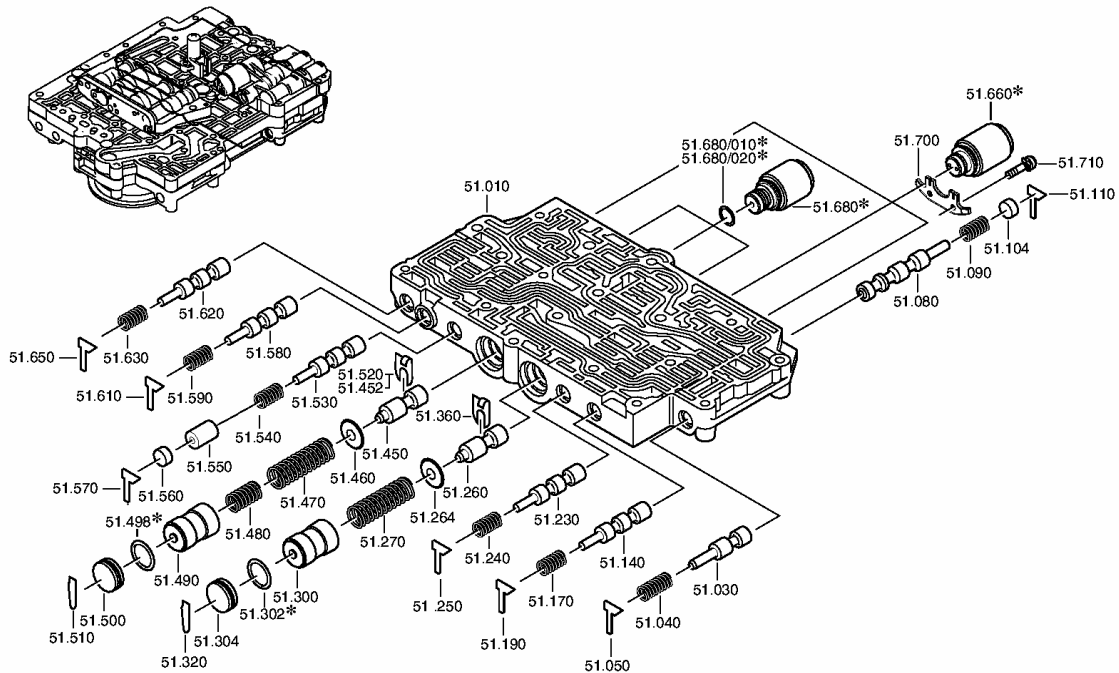

Note: Parts marked with * are only available in kits.



5HP19FLA Valve Body – Valve Housing Groups (continued)

Pos #	ZF Part #	Description	Qty	Where used (1060 040 __)	Notes
51.610	1068 327 007	Support Plate	1	All	
51.620	1056 327 028	Piston	1	All	
51.630	0732 041 462	Compression Spring	1	002/012/013/018/036	
	0732 041 826	Compression Spring	1	030/035/044/053/054/ 063/065/073/075/087/ 093/100/101/103	
51.650	1068 327 007	Support Plate	1	All	
51.660	0501 316 463	Solenoid Valve	3	030/035/044/053/054/ 063/065/073/075/087/ 093/100/101/103	* Available in kit 1060 298 033
	0750 132 122	Solenoid Valve	3	002/012/013/018/036	* Available in kit 1060 298 035
51.680	0501 208 542	Pressure Regulator	3	002/012/013/018/036	* Available in kit 1060 298 035
	0501 210 019	Pressure Regulator	3	030/035/044/053/054/ 063/065/073/075/087/ 093/100/101/103	* Available in kit 1060 298 033
51.680/010	0734 313 219	O-Ring	3	030/035/044/053/054/ 063/065/073/075/087/ 093/100/101/103	* Available in kit 1060 298 031 * Available in kit 1060 298 033
51.680/020	0734 313 134	O-Ring	3	002/012/013/018/036	* Available in kit 1060 298 031 * Available in kit 1060 298 035
51.700	1056 327 135	Fixing Plate	2	All	
51.710	0736 101 094	Torx Screw M5x12	4	All	

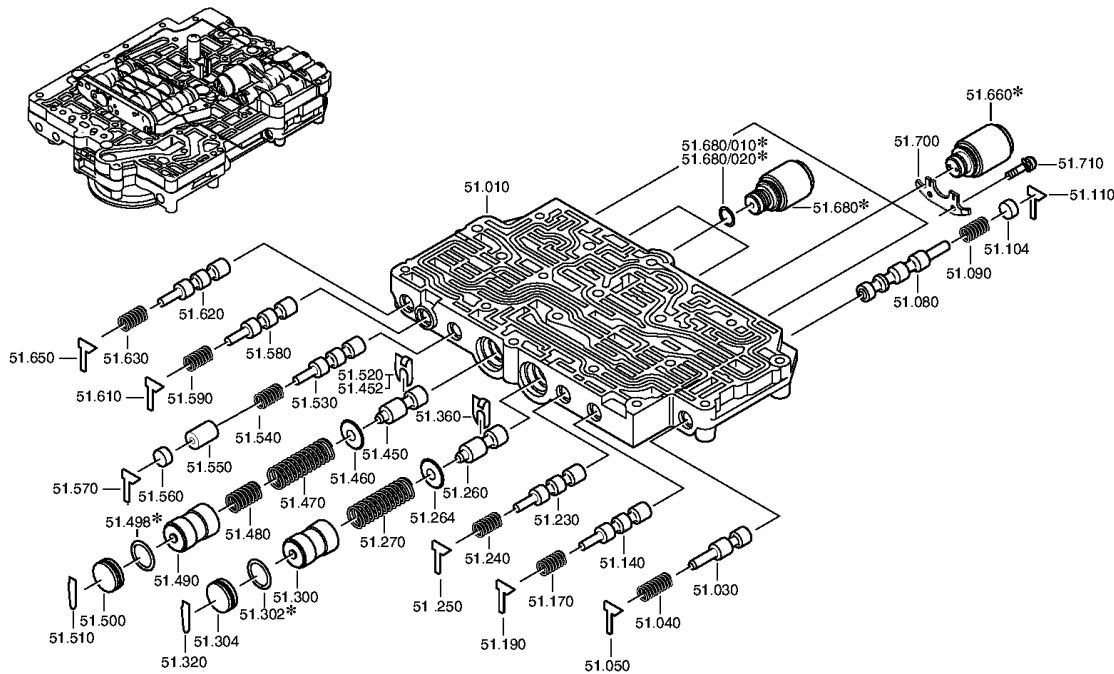

Note: Parts marked with * are only available in kits.



5HP19FLA Valve Body – Valve Housing Groups (continued)

Pos #	ZF Part #	Description	Qty	Where used (1060 040 ___)	Notes
53.010	1056 328 015	Valve Housing	1	002/018	
	1060 327 003	Valve Housing	1	012/013/036	
	1060 327 098	Valve Housing	1	030/035/054/065/073/101	
	1060 327 110	Valve Housing	1	093	
	1060 327 113	Valve Housing	1	044/053/063/075/087/100/103	
53.020	0732 041 337	Compression Spring	1	044/053/063/075/087/093/100/103	
	0732 041 970	Compression Spring	1	002/012/013/018/036	
	0732 042 567	Compression Spring	1	030/035/054/065/073/101	
53.030	1055 327 015	Piston	1	044/053/063/075/087/093/100/103	
	1055 327 059	Piston	1	030/035/054/065/073/101	
	1056 328 016	Piston	1	002/012/013/018/036	
53.080	0732 041 109	Compression Spring	1	030/035/044/053/054/063/065/073/075/087/100/101/103	
	0732 041 726	Compression Spring	1	093	
	0732 042 382	Compression Spring	1	002/012/013/018/036	
53.090	1056 327 004	Piston	1	012/013/036	
	1056 327 148	Piston	1	002/018	
	1058 327 024	Piston	1	030/035/044/053/054/063/065/073/075/087/100/101/103	
	1060 327 111	Piston	1	093	

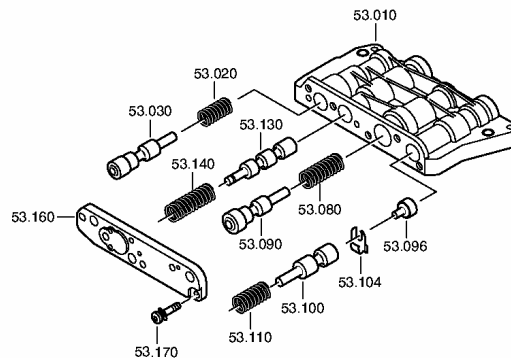
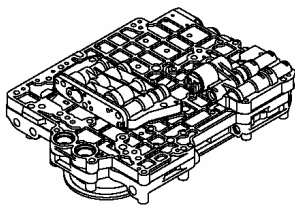

Note: Parts marked with * are only available in kits.



5HP19FLA Valve Body – Valve Housing Groups (continued)

Pos #	ZF Part #	Description	Qty	Where used (1060 040 ___)	Notes
53.096	1055 327 098	Piston	1	002/012/013/018/036	
	1060 327 104	Piston	1	030/035/044/053/054/ 063/065/073/075/087/ 093/100/101/103	
53.100	1043 327 078	Piston	1	All	
53.104	1056 327 075	Stop Plate	1	All	
53.110	0732 042 534	Compression Spring	1	All	
53.130	1060 327 045	Piston	1	All	
53.140	0732 041 781	Compression Spring	1	030/035/044/053/054/ 063/065/073/075/087/ 093/100/101/103	
	0732 042 477	Compression Spring	1	002/012/013/018/036	
53.160	1056 327 131	Cover	1	002/012/013/018/036	
	1060 327 050	Cover	1	030/035/044/053/054/ 063/065/073/075/087/ 093/100/101/103	
53.170	0736 101 066	Torx Screw M5x18	5	All	

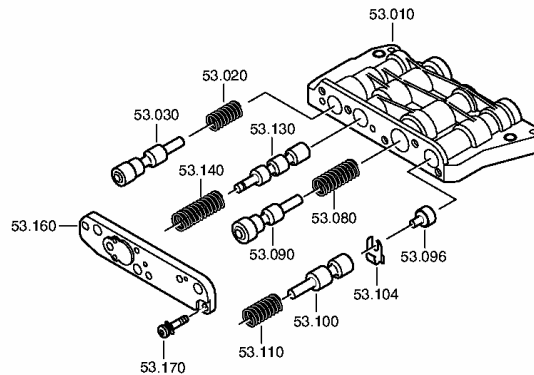
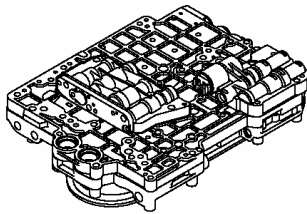

Note: Parts marked with * are only available in kits.



5HP19FLA Valve Body – Valve Housing Groups (continued)

Pos #	ZF Part #	Description	Qty	Where used (1060 040 ___)	Notes
54.010	1060 327 043	Valve Housing	1	002/012/013/018/036	
	1060 327 081	Valve Housing	1	030/035/054/065/073/101	
	1060 327 085	Valve Housing	1	044/053/063/075/087/093/100/103	
54.020	0732 042 567	Compression Spring	1	All	
54.030	1056 328 013	Piston	1	All	
54.034	0732 042 568	Compression Spring	1	All	
54.036	1056 327 177	Piston	1	030/035/054/065/073/101	
	1056 328 025	Piston	1	002/012/013/018/036	
	1060 327 086	Piston	1	044/053/063/075/087/093/100/103	
54.040	1043 326 307	Plug	1	002/012/013/018/036	
	1043 327 053	Plug	1	030/035/054/065/073/101	
	1043 327 087	Plug	1	044/053/063/075/087/093/100/103	
54.050	1068 327 007	Support Plate	1	All	

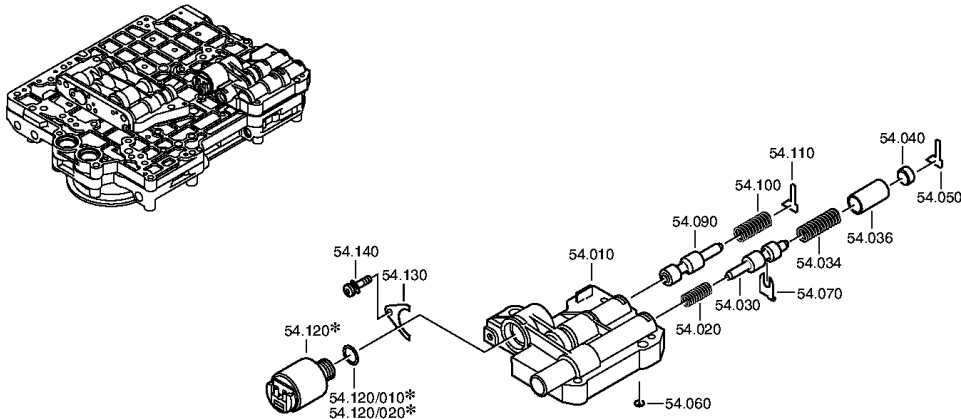

Note: Parts marked with * are only available in kits.



5HP19FLA Valve Body – Valve Housing Groups (continued)

Pos #	ZF Part #	Description	Qty	Where used (1060 040 ____)	Notes
54.060	1060 327 044	Valve Orifice D=1.2	1	All	
54.070	1060 327 126	Stop Plate	1	All	
54.090	1043 326 169	Valve Spool	1	All	
54.100	0732 041 819	Compression Spring	1	030/035/044/053/054/ 063/065/073/075/087/ 093/100/101/103	
	0732 042 504	Compression Spring	1	002/012/013/018/036	
54.110	1068 327 007	Support Plate	1	All	
54.120	0501 209 875	Pressure Regulator	1	002/012/013/018/036	* Available in kit 1060 298 035
	0501 210 725	Pressure Regulator	1	030/035/044/053/054/ 063/065/073/075/087/ 093/100/101/103	* Available in kit 1060 298 033
54.120/010	0634 316 523	O-Ring	1	030/035/044/053/054/ 063/065/073/075/087/ 093/100/101/103	* Available in kit 1060 298 033
54.120/020	0734 313 220	O-Ring	1	002/012/013/018/036	* Available in kit 1060 298 031 * Available in kit 1060 298 035
54.130	1019 327 065	Fixing Plate	1	All	
54.140	0736 101 094	Torx Screw M5x12	1	All	

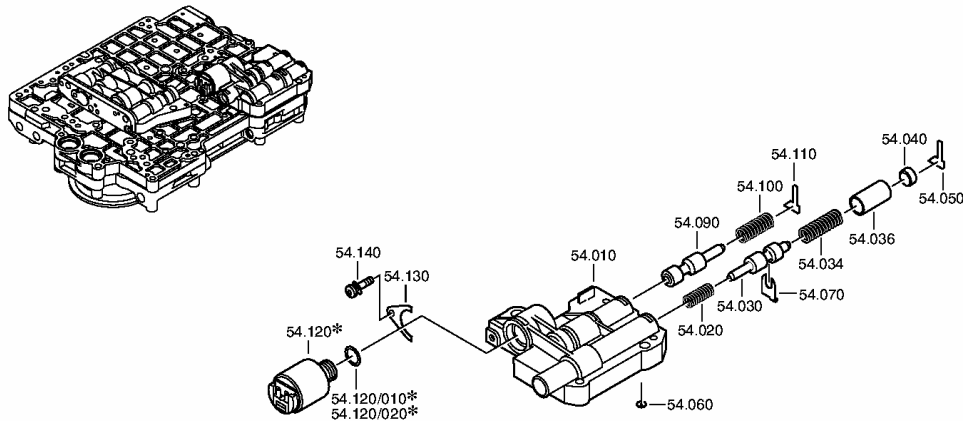

Note: Parts marked with * are only available in kits.



5HP19FLA Selective Shims & Snap Rings

5HP19FLA Selective Snap Ring

Pos #	Select. Parts	Description	Qty	Where used (1060 030 ___)
10.340		Clutch C Snap Ring	1	All
	1056 310 054	Snap Ring A=1.40		
	1056 310 055	Snap Ring A=1.60		
	1056 310 056	Snap Ring A=1.80		
	1056 310 057	Snap Ring A=2.00		
	1056 310 058	Snap Ring A=2.20		
	1056 310 059	Snap Ring A=2.40		
	1056 310 060	Snap Ring A=2.60		
	1056 310 097	Snap Ring A=2.80		

5HP19FLA Selective Shim

Pos #	Select. Parts	Description	Qty	Where used (1060 040 ___)
10.400		Intermediate Plate Shim	1	All
	0730 105 263	Shim A=1.00		
	0730 105 264	Shim A=1.20		
	0730 105 265	Shim A=1.40		
	0730 105 266	Shim A=1.60		
	0730 105 267	Shim A=1.80		
	0730 105 268	Shim A=2.00		
	0730 105 269	Shim A=2.20		
	0730 105 270	Shim A=2.40		
	0730 105 271	Shim A=2.60		
	0730 105 272	Shim A=2.80		
	0730 105 273	Shim A=3.00		
	0730 105 274	Shim A=3.20		
	0730 105 275	Shim A=3.40		
	0730 105 276	Shim A=3.60		

5HP19FLA Selective Shim

Pos #	Select. Parts	Description	Qty	Where used (1060 040 ___)
35.040		Pinion Bearing Shim	1	All
	0730 007 517	Shim A=0.97		
	0730 007 518	Shim A=1.00		
	0730 007 519	Shim A=1.03		
	0730 007 520	Shim A=1.06		
	0730 007 521	Shim A=1.09		
	0730 007 522	Shim A=1.12		
	0730 007 523	Shim A=1.15		
	0730 007 524	Shim A=1.18		
	0730 007 525	Shim A=1.21		
	0730 007 526	Shim A=1.24		
	0730 007 527	Shim A=1.27		
	0730 007 528	Shim A=1.30		
	0730 007 529	Shim A=1.33		
	0730 007 530	Shim A=1.36		
	0730 007 531	Shim A=1.39		
	0730 007 532	Shim A=1.42		



5HP19FLA Selective Shims & Snap Rings (continued)

5HP19FLA Selective Shim (continued)

Pos #	Select. Parts	Description	Qty	Where used (1060 040 ___)
35.040		Pinion Bearing Shim	1	All
	0730 007 533	Shim A=1.45		
	0730 007 534	Shim A=1.48		
	0730 007 535	Shim A=1.51		
	0730 007 536	Shim A=1.54		
	0730 007 537	Shim A=1.57		
	0730 007 538	Shim A=1.60		
	0730 007 539	Shim A=1.63		
	0730 007 540	Shim A=1.66		
	0730 007 541	Shim A=1.69		
	0730 007 542	Shim A=1.72		
	0730 007 543	Shim A=1.75		
	0730 007 544	Shim A=1.78		
	0730 007 545	Shim A=1.81		
	0730 007 546	Shim A=1.84		
0730 007 547	Shim A=1.87			

5HP19FLA Selective Shim

Pos #	Select. Parts	Description	Qty	Where used (1060 040 ___)
35.080		Diff. Bearing Shim	1	All
	0730 005 451	Shim A=1.00		
	0730 009 638	Shim A=1.02		
	0730 005 452	Shim A=1.05		
	0730 009 639	Shim A=1.07		
	0730 005 453	Shim A=1.10		
	0730 009 640	Shim A=1.12		
	0730 005 454	Shim A=1.15		
	0730 009 641	Shim A=1.17		
	0730 005 455	Shim A=1.20		
	0730 009 642	Shim A=1.22		
	0730 005 456	Shim A=1.25		
	0730 009 643	Shim A=1.27		
	0730 005 457	Shim A=1.30		
	0730 009 644	Shim A=1.32		
	0730 005 458	Shim A=1.35		
	0730 009 645	Shim A=1.37		
	0730 005 459	Shim A=1.40		
	0730 009 646	Shim A=1.42		
	0730 005 460	Shim A=1.45		
	0730 009 647	Shim A=1.47		
	0730 005 461	Shim A=1.50		
	0730 009 648	Shim A=1.52		
	0730 005 462	Shim A=1.55		
	0730 009 649	Shim A=1.57		
	0730 007 549	Shim A=1.60		
	0730 009 650	Shim A=1.62		
	0730 007 550	Shim A=1.65		
0730 009 651	Shim A=1.67			



5HP19FLA Selective Shims & Snap Rings (continued)

5HP19FLA Selective Shim (continued)

Pos #	Select. Parts	Description	Qty	Where used (1060 040 ___)
35.080		Diff. Bearing Shim	1	All
	0730 007 551	Shim A=1.70		
	0730 009 652	Shim A=1.72		
	0730 007 552	Shim A=1.75		
	0730 009 653	Shim A=1.77		
	0730 007 553	Shim A=1.80		
	0730 009 654	Shim A=1.82		
	0730 007 554	Shim A=1.85		
	0730 009 655	Shim A=1.87		
	0730 007 555	Shim A=1.90		
	0730 009 656	Shim A=1.92		
	0730 007 556	Shim A=1.95		

5HP19FLA Selective Shim

Pos #	Select. Parts	Description	Qty	Where used (1060 040 ___)
35.120		Diff. Cover Shim	1	All
	0730 005 962	Shim A=1.00		
	0730 009 657	Shim A=1.02		
	0730 005 963	Shim A=1.05		
	0730 009 658	Shim A=1.07		
	0730 005 964	Shim A=1.10		
	0730 009 659	Shim A=1.12		
	0730 005 965	Shim A=1.15		
	0730 009 660	Shim A=1.17		
	0730 005 966	Shim A=1.20		
	0730 009 661	Shim A=1.22		
	0730 005 967	Shim A=1.25		
	0730 009 662	Shim A=1.27		
	0730 005 968	Shim A=1.30		
	0730 009 663	Shim A=1.32		
	0730 005 969	Shim A=1.35		
	0730 009 664	Shim A=1.37		
	0730 005 970	Shim A=1.40		
	0730 005 970	Shim A=1.40		
	0730 009 665	Shim A=1.42		
	0730 009 665	Shim A=1.42		
	0730 005 971	Shim A=1.45		
	0730 005 971	Shim A=1.45		
	0730 009 666	Shim A=1.47		
	0730 009 666	Shim A=1.47		
	0730 005 972	Shim A=1.50		
	0730 005 972	Shim A=1.50		
	0730 009 667	Shim A=1.52		
	0730 009 667	Shim A=1.52		
	0730 005 973	Shim A=1.55		
	0730 005 973	Shim A=1.55		
	0730 009 668	Shim A=1.57		
	0730 009 668	Shim A=1.57		



5HP19FLA Selective Shims & Snap Rings (continued)

5HP19FLA Selective Shim (continued)

Pos #	Select. Parts	Description	Qty	Where used (1060 040 ___)
35.120		Diff. Cover Shim	1	All
	0730 005 974	Shim A=1.60		
	0730 005 974	Shim A=1.60		
	0730 009 669	Shim A=1.62		
	0730 009 669	Shim A=1.62		
	0730 005 975	Shim A=1.65		
	0730 005 975	Shim A=1.65		
	0730 009 670	Shim A=1.67		
	0730 005 976	Shim A=1.70		
	0730 009 671	Shim A=1.72		
	0730 005 977	Shim A=1.75		
	0730 009 672	Shim A=1.77		
	0730 005 978	Shim A=1.80		
	0730 009 673	Shim A=1.82		
	0730 005 979	Shim A=1.85		
	0730 009 674	Shim A=1.87		
	0730 005 980	Shim A=1.90		

5HP19FLA Selective Shim

Pos #	Select. Parts	Description	Qty	Where used (1060 040 ___)
35.330		Idler Gear Shim	1	All
35.350		Pinion Gear Shim		
	0730 007 577	Shim A=1.00		
	0730 007 578	Shim A=1.05		
	0730 007 579	Shim A=1.10		
	0730 007 580	Shim A=1.15		
	0730 007 581	Shim A=1.20		
	0730 007 582	Shim A=1.25		
	0730 007 583	Shim A=1.30		
	0730 007 584	Shim A=1.35		
	0730 007 585	Shim A=1.40		
	0730 007 586	Shim A=1.45		
	0730 007 587	Shim A=1.50		
	0730 007 588	Shim A=1.55		
	0730 007 589	Shim A=1.60		
	0730 007 590	Shim A=1.65		
	0730 007 591	Shim A=1.70		
	0730 007 592	Shim A=1.75		
	0730 007 593	Shim A=1.80		
	0730 007 594	Shim A=1.85		
	0730 007 595	Shim A=1.90		
	0730 007 596	Shim A=1.95		
	0730 007 597	Shim A=2.00		



5HP19FLA Selective Shims & Snap Rings (continued)

5HP19FLA Selective Shim

Pos #	Select. Parts	Description	Qty	Where used (1060 040 ___)
35.340		Output Shaft Gear Shim	1	All
	0730 007 598	Shim A=1.00		
	0730 007 599	Shim A=1.05		
	0730 008 068	Shim A=1.10		
	0730 008 069	Shim A=1.15		
	0730 008 070	Shim A=1.20		
	0730 008 071	Shim A=1.25		
	0730 008 072	Shim A=1.30		
	0730 008 073	Shim A=1.35		
	0730 008 074	Shim A=1.40		
	0730 008 075	Shim A=1.45		
	0730 008 076	Shim A=1.50		
	0730 008 077	Shim A=1.55		
	0730 008 078	Shim A=1.60		
	0730 008 079	Shim A=1.65		
	0730 008 080	Shim A=1.70		
	0730 008 081	Shim A=1.75		
	0730 008 082	Shim A=1.80		
	0730 008 083	Shim A=1.85		
	0730 008 084	Shim A=1.90		

5HP19FLA Selective Shim

Pos #	Select. Parts	Description	Qty	Where used (1060 040 ___)
37.040		Output Shim	1	All
	0730 007 837	Shim A=6.20		
	0730 007 838	Shim A=6.40		
	0730 007 839	Shim A=6.60		
	0730 007 840	Shim A=6.80		
	0730 007 841	Shim A=7.00		
	0730 007 842	Shim A=7.20		
	0730 007 843	Shim A=7.40		
	0730 007 844	Shim A=7.60		
	0730 007 845	Shim A=7.80		
	0730 007 846	Shim A=8.00		
	0730 007 847	Shim A=8.20		
	0730 007 848	Shim A=8.40		
	0730 007 849	Shim A=8.60		



5HP19FLA Selective Shims & Snap Rings (continued)

5HP19FLA Selective Snap Ring

Pos #	Select. Parts	Description	Qty	Where used (1060 040 ___)
70.010/230		Clutch A Snap Ring	1	All
	0730 513 293	Snap Ring A=1.00		
	0730 513 294	Snap Ring A=1.20		
	0730 513 295	Snap Ring A=1.40		
	0730 513 296	Snap Ring A=1.60		
	0730 513 297	Snap Ring A=1.80		
	0730 513 298	Snap Ring A=2.00		
	0730 513 299	Snap Ring A=2.20		
	0730 513 300	Snap Ring A=2.40		
	0730 513 301	Snap Ring A=2.60		
	0730 513 302	Snap Ring A=2.80		

5HP19FLA Selective Snap Ring

Pos #	Select. Parts	Description	Qty	Where used (1060 040 ___)
71.130		Clutch E Snap Ring	1	All
	0730 513 613	Snap Ring A=1.00		
	0730 513 614	Snap Ring A=1.20		
	0730 513 615	Snap Ring A=1.40		
	0730 513 567	Snap Ring A=1.50		
	0730 513 616	Snap Ring A=1.60		
	0730 513 617	Snap Ring A=1.80		
	0730 513 618	Snap Ring A=2.00		
	0730 513 619	Snap Ring A=2.20		
	0730 513 620	Snap Ring A=2.40		
	0730 513 621	Snap Ring A=2.60		
	0730 513 622	Snap Ring A=2.80		

5HP19FLA Selective Snap Ring

Pos #	Select. Parts	Description	Qty	Where used (1060 040 ___)
72.100		Clutch B Snap Ring	1	All
	1056 372 069	Snap Ring A=1.00		
	1056 372 070	Snap Ring A=1.20		
	1056 372 071	Snap Ring A=1.40		
	1056 372 072	Snap Ring A=1.60		
	1056 372 073	Snap Ring A=1.80		
	1056 372 074	Snap Ring A=2.00		
	1056 372 097	Snap Ring A=2.20		



5HP19FLA Selective Shims & Snap Rings (continued)

5HP19FLA Selective Snap Ring

Pos #	Select. Parts	Description	Qty	Where used (1060 030 ___)
73.010/200		Clutch D Snap Ring	1	All
	0730 513 299	Snap Ring A=2.20		
	0730 513 300	Snap Ring A=2.40		
	0730 513 301	Snap Ring A=2.60		
	0730 513 302	Snap Ring A=2.80		
	0730 513 362	Snap Ring A=3.00		
	0730 513 364	Snap Ring A=4.00		
	0730 513 568	Snap Ring A=3.20		
	0730 513 569	Snap Ring A=3.40		
	0730 513 570	Snap Ring A=3.60		
	0730 513 571	Snap Ring A=3.80		
	0730 513 667	Snap Ring A=4.20		

5HP19FLA Selective Snap Ring

Pos #	Select. Parts	Description	Qty	Where used (1060 030 ___)
73.080		Clutch G Snap Ring	1	All
	0730 513 212	Snap Ring A=1.80		
	0730 513 220	Snap Ring A=2.00		
	0730 513 221	Snap Ring A=2.20		
	0730 513 222	Snap Ring A=2.40		
	0730 513 223	Snap Ring A=2.60		
	0730 513 224	Snap Ring A=2.80		
	0730 513 439	Snap Ring A=3.00		
	0730 513 440	Snap Ring A=3.20		
	0730 513 441	Snap Ring A=3.40		

5HP19FLA Selective Snap Ring

Pos #	Select. Parts	Description	Qty	Where used (1060 040 ___)
77.010/210		Clutch F Snap Ring	1	All
	0730 513 210	Snap Ring A=1.20		
	0730 513 211	Snap Ring A=1.40		
	0730 513 219	Snap Ring A=1.60		
	0730 513 212	Snap Ring A=1.80		
	0730 513 220	Snap Ring A=2.00		
	0730 513 221	Snap Ring A=2.20		
	0730 513 222	Snap Ring A=2.40		
	0730 513 223	Snap Ring A=2.60		
	0730 513 224	Snap Ring A=2.80		



5HP19FLA Kit Content

5HP19FLA Fiber Clutch Kit – 1060 298 022

Pos #	ZF Part #	Description	Qty	Where used (1060 040 ___)	Notes
10.300	1060 210 037	Friction Plate C	5	030/035/044/053/054/ 063/065/073/075/087/ 093/100/101/103	030/054/065/073/101 use 3 pieces
70.010/210	1060 270 039	Friction Plate A	5	030/035/044/053/054/ 063/065/073/075/087/ 093/100/101/103	030/054/073/101 use 4 pieces
71.110	1060 271 008	Friction Plate E	5	030/035/044/053/054/ 063/065/073/075/087/ 093/100/101/103	030/054/073/101 use 4 pieces
72.080	1060 272 009	Friction Plate B	2	030/035/044/053/054/ 063/065/073/075/087/ 093/100/101/103	
73.010/180	1060 273 023	Friction Plate D	6	030/035/044/053/054/ 063/065/073/075/087/ 093/100/101/103	030/054/073/101 use 5 pieces
73.060	1060 277 031	Friction Plate G	4	030/035/044/053/054/ 063/065/073/075/087/ 093/100/101/103	030/054/073/101 use 3 pieces
77.010/200	1060 277 031	Friction Plate F	5	030/035/044/053/054/ 063/065/073/075/087/ 093/100/101/103	030/054/073/101 use 4 pieces

5HP19FLA Fiber Clutch Kit – 1060 298 024

Pos #	ZF Part #	Description	Qty	Where used (1060 040 ___)	Notes
10.300	1019 273 019	Friction Plate C	5	002/012/013/018/036	002/018 use 4 pieces
70.010/210	1050 202 002	Friction Plate A	5	002/012/013/018/036	018 uses 4 pieces
71.110	1050 230 032	Friction Plate E	5	002/012/013/018/036	018 uses 4 pieces
72.080	1060 272 003	Friction Plate B	2	002/012/013/018/036	
73.010/180	1050 217 002	Friction Plate D	6	002/012/013/018/036	002/012/013/018/036 use 5 pieces
73.060	1056 277 036	Friction Plate G	4	002/012/013/018/036	018 uses 3 pieces
77.010/200	1056 277 036	Friction Plate F	5	002/012/013/018/036	018 uses 4 pieces

5HP19FLA Steel Kit – 1060 298 025

Pos #	ZF Part #	Description	Qty	Where used (1060 040 ___)	Notes
10.290	1060 310 027	Steel Plate C	3	030/035/054/065/073/ 101	
10.310	1060 310 027	End Plate C	1	030/035/054/065/073/ 101	
70.010/200	1060 370 002	Steel Plate A	5	All	030/054/073/101 use 4 pieces
70.010/220	1060 370 003	End Plate A	1	All	
71.100	1060 371 002	Steel Plate E	5	All	030/054/073/101 use 4 pieces
71.120	1060 371 003	End Plate E	1	All	
72.070	1060 372 002	Steel Plate B	2	All	
72.090	1060 372 003	End Plate B	1	All	
73.010/170	1060 370 002	Steel Plate D	6	All	030/054/073/101 use 4 pieces
73.010/190	1060 370 003	End Plate D	1	All	
73.050	1060 377 003	Steel Plate G	4	All	030/054/073/101 use 3 pieces

Note: Above listed parts are not sold individually.



5HP19FLA Kit Content (continued)

5HP19FLA Steel Kit – 1060 298 025 (continued)

Pos #	ZF Part #	Description	Qty	Where used (1060 040 ____)	Notes
73.070	1060 377 004	End Plate G	1	All	
77.010/190	1060 377 002	Steel Plate F	6	All	030/054/073/101 use 5 pieces

5HP19FLA Steel Kit – 1060 298 026

Pos #	ZF Part #	Description	Qty	Where used (1060 040 ____)	Notes
10.290	1060 310 004	Steel Plate C	5	002/012/013/018/036/ 044/053/063/075/087/ 093/100/103	002/018 use 4 pieces
10.310	1060 310 005	End Plate C	1	002/012/013/018/036/ 044/053/063/075/087/ 093/100/103	
70.010/200	1060 370 002	Steel Plate A	5	All	018 uses 4 pieces
70.010/220	1060 370 003	End Plate A	1	All	
71.100	1060 371 002	Steel Plate E	5	All	018 uses 4 pieces
71.120	1060 371 003	End Plate E	1	All	
72.070	1060 372 002	Steel Plate B	2	All	
72.090	1060 372 003	End Plate B	1	All	
73.010/170	1060 370 002	Steel Plate D	6	All	002/012/013/018/036 use 5 pieces
73.010/190	1060 370 003	End Plate D	1	All	
73.050	1060 377 003	Steel Plate G	4	All	018 uses 3 pieces
73.070	1060 377 004	End Plate G	1	All	
77.010/190	1060 377 002	Steel Plate F	6	All	018 uses 5 pieces

5HP19FLA Overhaul Kit – 1060 298 031

Pos #	ZF Part #	Description	Qty	Where used (1060 040 ____)	Notes
01.010/130	0734 313 060	O-Ring	2	All	
01.250	0734 319 624	Shaft Seal	1	All	
01.260	0501 318 572	Screw Plug M10x1	1	All	
01.270	0734 317 268	Sealing Sleeve	5	All	
01.280	0734 317 227	Sealing Sleeve	3	All	
03.020	1056 303 031	Gasket	1	All	
03.120	0636 308 026	Screw Plug M16x1.5	1	All	
03.130	0734 313 176	O-Ring	1	All	
10.010/160	0734 310 316	Shaft Seal	1	All	
10.030	0734 313 178	O-Ring	1	All	
10.190	0734 313 006	O-Ring	1	All	
10.200	0734 313 117	O-Ring	1	All	
10.360	0734 313 162	O-Ring	1	All	
10.370	0734 401 158	Piston Ring	2	All	
10.380	0734 401 213	Piston Ring	1	All	
10.440	0750 112 076	Usit Ring	9	All	
27.188	0501 314 645	Rubber Part	1	All	Early valve body
	1068 227 039	Piston	1	All	Late valve body

Note: Above listed parts are not sold individually.



5HP19FLA Kit Content (continued)

5HP19FLA Overhaul Kit – 1060 298 031 (continued)

Pos #	ZF Part #	Description	Qty	Where used (1060 040 ___)	Notes
27.198	0501 314 645	Rubber Part	1	All	Early valve body
	1068 227 039	Piston	1	All	Late valve body
27.208	0501 314 645	Rubber Part	1	All	Early valve body
	1068 227 039	Piston	1	All	Late valve body
27.220	1060 327 069	Gasket	1	002/012/013/018/036 030/035/044/053/054/ 063/065/073/075/087/ 093/100/101/103	
	1060 327 090	Gasket	1		
27.340/116	0501 209 253	O-Ring	2	All	
27.420/020	0501 314 578	Sealing Ring	1	All	
35.070	0750 111 399	Shaft Seal	1	All	
35.146	0734 313 155	O-Ring	1	All	
35.150/120	0734 310 342	Shaft Seal	1	All	
35.220/120	0734 319 419	Shaft Seal	1	All	
35.230/020	0501 313 484	O-Ring	2	All	
35.240	0734 317 262	Sealing Ring	1	All	
35.280	0734 319 529	Shaft Seal	1	All	
35.370	0636 308 025	Screw Plug M18x1.5	1	All	
36.220	0734 307 291	Sealing Ring	1	All	
36.230/120	0734 319 588	Shaft Seal	1	All	
36.280	1058 336 021	Gasket	1	All	
36.340	0636 308 024	Screw Plug M12x1.5	1	All	
36.350	0636 308 025	Screw Plug M12x1.5	1	All	
37.010	1056 337 013	Gasket	1	All	
37.080/120	0734 319 604	Shaft Seal	1	All	
37.240	0734 319 547	Double Seal	1	All	
51.302	0734 313 190	O-Ring	1	All	
51.498	0734 313 090	O-Ring	1	All	
51.680/010	0734 313 219	O-Ring	3	030/035/044/053/054/ 063/065/073/075/087/ 093/100/101/103	
51.680/020	0734 313 134	O-Ring	3	002/012/013/018/036	
54.120/020	0734 313 220	O-Ring	1	002/012/013/018/036	
70.010/120	0734 313 014	O-Ring	1	All	
70.010/130	0734 313 029	O-Ring	1	All	
70.020	0734 313 163	O-Ring	1	All	
71.020	0734 317 256	Piston Ring	1	All	
71.030	0734 317 190	Sealing Ring	1	All	
71.060	0734 313 022	O-Ring	1	All	
71.070	0734 313 027	O-Ring	1	All	
71.086	0734 313 008	O-Ring	1	All	
71.150	0734 313 160	O-Ring	1	All	
71.160	0734 313 211	O-Ring	1	All	
72.050	0734 313 010	O-Ring	1	All	
72.060	0734 313 007	O-Ring	1	All	
73.010/130	0301 302 059	O-Ring	1	All	
73.010/140	0734 313 006	O-Ring	1	All	
73.022	0734 313 021	O-Ring	1	All	

Note: Above listed parts are not sold individually.



5HP19FLA Kit Content (continued)

5HP19FLA Overhaul Kit – 1060 298 031 (continued)

Pos #	ZF Part #	Description	Qty	Where used (1060 040 ___)	Notes
73.024	0734 313 010	O-Ring	1	All	
73.100/140	0734 313 086	O-Ring	2	All	
73.130	0734 317 205	Piston Ring	1	All	
73.140	0734 317 205	Piston Ring	1	All	
77.010/130	0734 313 008	O-Ring	1	All	
77.010/140	0734 313 010	O-Ring	1	All	
77.010/230	0734 313 135	O-Ring	1	All	Use with early Cylinder F
77.010/250	0734 317 219	Piston Ring	1	All	Use with early Cylinder F

5HP19FLA Solenoid Kit – 1060 298 033

Pos #	ZF Part #	Description	Qty	Where used (1060 040 ___)	Notes
51.660	0501 316 463	Solenoid Valve	3	030/035/044/053/054/ 063/065/073/075/087/ 093/100/101/103	
51.680	0501 210 019	Pressure Regulator	3	030/035/044/053/054/ 063/065/073/075/087/ 093/100/101/103	
51.680/010	0734 313 219	O-Ring	3	030/035/044/053/054/ 063/065/073/075/087/ 093/100/101/103	
54.120	0501 210 725	Pressure Regulator	1	030/035/044/053/054/ 063/065/073/075/087/ 093/100/101/103	
54.120/010	0634 316 523	O-Ring	1	030/035/044/053/054/ 063/065/073/075/087/ 093/100/101/103	

5HP19FLA Solenoid Kit – 1060 298 035

Pos #	ZF Part #	Description	Qty	Where used (1060 040 ___)	Notes
51.660	0750 132 122	Solenoid Valve	3	002/012/013/018/036	
51.680	0501 208 542	Pressure Regulator	4	002/012/013/018/036	002/012/013/018/036 use 3 pieces
51.680/020	0734 313 134	O-Ring	4	002/012/013/018/036	
54.120	0501 209 875	Pressure Regulator	1	002/012/013/018/036	
54.120/020	0734 313 220	O-Ring	1	002/012/013/018/036	

5HP19FLA Filter Kit – 5HP19FKFL

Pos #	ZF Part #	Description	Qty	Where used (1060 040 ___)	Notes
03.020	1056 303 031	Gasket	1	All	
03.120	0636 308 026	Screw Plug M16x1.5	1	All	
03.130	0636 302 102	Screw Plug M30x1.5	1	All	
	0734 313 176	O-Ring	1	All	
27.420	0501 209 251	Filter	1	All	
27.420/020	0501 314 578	Sealing Ring	1	All	

Note: Above listed parts are not sold individually.



Quotation / Order Form

FAX FORM TO YOUR PREFERRED ZF PASSENGER CAR TRANSMISSION DISTRIBUTOR

Purchase Order Date: _____

Purchase Order #: _____

Customer Information

Company Name: _____

Contact: _____

Street: _____

City, State & Zip: _____

Phone #: _____

Fax #: _____

Email: _____

Customer #: _____

Shipping Information

Ship To: _____

Attention: _____

Street: _____

City, State & Zip: _____

Request Date: _____

Ship via: _____

Vehicle Information

Make: _____

Model: _____

Model Year: _____

Transmission Spec: _____

Order Information

Line	Qty	Pos. #	ZF Part #	Description / Cust. Ref. No.
1				
2				
3				
4				
5				
6				
7				
8				
9				
10				
11				
12				
13				
14				
15				
16				
17				
18				
19				
20				

Signature: _____

Date: _____



Notes



Warranty Information

Warranty coverage for ZF passenger car transmission spare parts and kits covers the first 12 months after installation in the vehicle, or 24 months after purchase from ZF Industries, Inc.

Warranty of the product is limited to replacement or repair, if found to be defective in ZF material or workmanship, and specifically does not cover removal, reinstallation, or any costs incidental to the repair of the vehicle, or any kind of consequential damages.

All warranty and/or non-warranty returns must be approved.

Disclaimer

The specifications and information shown in this catalog have been compiled from accepted and reliable sources and is believed to be accurate at the time of publication. While ZF Industries, Inc. believes this information is correct, no guarantee or warranty is made as to the accuracy of the information and ZF Industries, Inc. cannot and does not accept or assume any responsibilities for errors, omissions, or consequential harm or damages. Replacement parts should not be used when they do not appear to fit. ZF Industries, Inc. disclaims all liability and responsibility for any harm resulting from any such modifications.

Copyright

Printed in USA – Copyright © 2003 ZF Industries, Inc.

No part of this publication may be reproduced, stored in a retrieval system, or transmitted, in any form or by any means, electronic, mechanical, photocopying, recording, or otherwise, without prior written permission of ZF Industries, Inc.