



Commercial  
Vehicles

# The Amarok





**A Dakar legend is born.**



Volkswagen Amarok was christened in the ochre dust of the famous Dakar Rally. What an initiation onto the world automotive stage. The Dakar is, without question, the toughest auto rally in the world. For the last thirty years and more, this race has created legends of riders, drivers and machines. Amarok just happens to be one of the latest amazing stories to emerge. Fresh off the production line, 35 Amaroks were

commissioned – 20 to support the Volkswagen race team, 15 to be used by the race organisation as the official support vehicle. Make no mistake, in The Dakar, support vehicles work almost as hard as race vehicles – and this was particularly so, as Amarok had to carry half a tonne of tools and repair equipment on-board throughout the event. After 15 torrid stages across 8,000km of uncompromising terrain in Argentina and

Chile, just 42% of all competitor cars finished in 2010. In the face of this substantial attrition rate, it's incredible to think that, aside from the odd air filter change or fuse replacement, all 35 Amaroks handled the challenge without a problem. And so behold – the latest Dakar legend: New Volkswagen Amarok. The newest member of the world renowned Volkswagen Commercial Vehicle family.





## The Amarok Range.

It's somewhat ironic that Amarok has proved itself in the deserts of South America given that its name translates to "arctic wolf" in the Inuit language.

The Eskimo people of Northern Canada and Greenland believe the mythical Amarok to be the king of the wild. It is agile, powerful and robust. It is a formidable beast that takes no backward step. In other words, the Volkswagen Amarok is aptly named.

Certainly, one part of the Amarok's personality is about being tough. After all, it is a world class ute created to match heavy-duty requirements. But the Amarok is also extremely smart, uniting unmatched cross-country mobility and efficiency in this segment.

Built on a robust ladder frame chassis and distinguished by the high standards of Volkswagen design, engineering and build quality, this uncompromising



ute is packed with clever technology beneath its svelte coat.

And the wolf has a big heart – you have the choice of either an efficient TDI340 turbo diesel engine or an even more powerful TDI400 Bi-turbo engine. Both engines have outstanding torque and achieve equally notable fuel and CO<sub>2</sub> efficiencies. Of course, power without control is nothing and this is where the 4MOTION all-wheel drive system makes

such a difference – particularly off-road. In this environment, you can step up the regular ABS and ESP settings by pressing an off-road button that optimises the handling and grip characteristics for off-road situations.

Huge space in the Amarok cabin for five is matched by enormous tray capacity. Uniquely, the Amarok accommodates a pallet between the wheel arches and boasts the largest load bay dimensions in

its segment. All this means you're able to carry a big team and an even bigger load to any job. Ride dynamics, a beautifully appointed interior and a full suite of features at the fingertips of the driver build an extremely compelling case for the Amarok range, which comprises four exciting variants.





## The inside story on the Amarok.

The cockpit of the Amarok is pure Volkswagen – a seamless blend of form and function. Understated. Elegant. Well considered. Practical. Ergonomic. It unites Volkswagen passenger vehicle comfort with robust Volkswagen commercial vehicle values.

The Amarok is essentially a potent combination of attributes that includes an impressive list of safety features. In addition to Anti-Lock Braking System (ABS), all models in the Volkswagen

Amarok range come with Electronic Differential Lock (EDL), Anti-Slip Regulation (ASR), Electronic Stabilisation Programme (ESP), Hill Start Assist and Hill Descent Assist. Height-adjustable head restraints and 3-point seatbelts are featured throughout, with pretensioners on the front seats. Add in front and head/thorax airbags for the driver and front passenger and it amounts to a 5 Star ANCAP rating. For driver and passengers alike, the Amarok is extremely quiet in the cabin, with limited road and



tyre noise invading the conversation. Which is just as well, as the conversation has to travel further in a cabin that is extremely spacious with ample leg and head room in the rear for taller adults. But the cabin isn't just roomy, it's also smart. A unique 'multifix clip' on the dashboard can be used to insert various accessories and plug-in parts, such as cupholders, picture holder and mounting for the bluetooth touch pad. The interior also carries up to three 12-volt power outlets to cater for a variety of

aftermarket power needs, with one of the points positioned on the top of the upper dash to cut cable tangle from aftermarket equipment.

The real treat in the interior is for the person behind the wheel. The Amarok's handling, and its steering in particular is brilliant. Volkswagen engineers have concentrated on providing the driver with an experience that is more like driving a top-class SUV than a workhorse. The Amarok feels more like a passenger

wagon – totally disguising its impressive heavy-duty credentials.

The ride is different too, thanks to highly engineered springs and rigid construction, which capably absorb the brunt of rough roads on the fly. All this means smooth, enjoyable driving, no matter what the conditions.





Vehicle shown with accessories.





# Amarok.

The entry level Amarok, in either rear-wheel drive or 4MOTION, is ready for tough challenges and takes a no-nonsense approach to every assignment. Those buyers looking for a 2WD variant will be pleased to learn that it has the very same ride height of its 4MOTION sibling. Now that's something you don't often find in this segment.

The Amarok is easy to maintain with comfortable, hardwearing Anthracite fabric seats, and a robust appearance. Unpainted front bumpers, door handles and mirrors put it right at home on the toughest work sites. The tailgate can drop right through to 180° on vehicles without towbar to make loading easier – particularly if you're using a forklift. If your worksite happens to be extra muddy, you can gear up your Amarok with optional selectable 4MOTION. Press the Off-road button to help maximise work output on loose surfaces.

All this talk of work doesn't mean the base model Amarok doesn't like a bit of fun too. It's got a mile of room in the tray for all kinds of recreational equipment. And that's not to mention the mile of room in the cabin either – a team of solid workers will be comfortable front and back with plenty of head and leg room.

Amarok comes equipped with 16-inch steel wheels, height-adjustable front seats, power windows, remote central locking, climatic air-conditioning, RCD310 CD player, variable folding rear bench seats, a lockable glove box, cargo platform lighting, centre armrest and an antenna integrated in the wing power mirrors.



# Amarok Trendline.

Amarok Trendline handles the dual work/play role so well with a range of additional features and a colour coded exterior that gives it a more refined appearance for all occasions.

Step up and into Trendline and enjoy additional features over the entry level model such as multi-functional display, cruise control, front fog lights, rear bar with step and 16-inch Taruma alloy wheels.

The comfortable seats of Amarok Trendline are upholstered in "Trail" fabric in Anthracite. And there are other fine touches throughout the cabin. A centre armrest makes long drives much more comfortable, and easy-to-access drawers under the front seats are a smart storage solution for smaller items.

Amarok Trendline might be more refined, but that doesn't mean it's any less capable off-road. Selectable 4MOTION technology will provide you with the low range capability to get you to places further afield.







Vehicle shown with accessories.



Vehicle shown with accessories.

## Amarok Highline.





If you're looking at making a statement on the worksite, Amarok Highline stamps your authority. The addition of chrome highlights on the mirror housings, the radiator grille, around the foglights and on the rear bumper bar accentuates the sleek design of the exterior.

Rear privacy glass, body coloured flared wheel houses and stylish 18-inch Durban alloy wheels complete the package.

Inside, the RCD510 touch screen audio keeps passengers entertained, while climatronic dual zone air-conditioning keeps them comfortable.

The interior climate is divided into two zones – for the driver and the front passenger – and the set temperatures are kept at a constant level by sensors, with the intensity of the sun also taken into account. That's smart German

thinking for harsh Australian conditions. With Amarok Highline, high-quality Anthracite upholstery is offset by leather clad steering wheel and gear lever knob. Amarok Highline cuts a fine figure on the road and is equally capable out on the range, thanks to Volkswagen's brilliant selectable 4MOTION technology with low range and Off-road mode. Security alarm and optional rear parking sensors combine to protect your investment.





## Amarok Ultimate.

The top of the range Amarok Ultimate has it all, with fine appointments throughout the cabin. The superb RCD510 touch screen audio system, together with the added comfort of full leather trim, makes Amarok Ultimate the perfect vehicle for long trips up the coast or short trips into town. Rear parking sensors enhance the enjoyable





driving experience and the security alarm will give you complete peace of mind.

Amarok is well known for its Dakar Rally performances, and the Amarok Ultimate offers the unique option of permanent 4MOTION to give you superior traction in the most trying conditions. That could

be on wet or snowy roads, or alternatively if you find yourself in something that resembles the depths of the South American desert.

Underfoot, 19-inch alloy Alustaro wheels provide your Amarok Ultimate with a sophisticated appearance that is as much

at home on the beach as it is arriving at a black tie event. Rear privacy glass, stainless steel sidesteps and a stainless steel sportsbar complete this picture and 'Ultimate' badging inside and out is a subtle reminder that you're driving the best equipped Amarok on the road.

## Exterior.

Amarok has the distinctive new Volkswagen family “face” with its recognisable front headlights and prominent badge position. Flared wheelhouses (standard on the Amarok Highline and Ultimate models) and sleek lines along the length of the vehicle also project a powerful, uncompromising image. But Amarok doesn’t just look great. It also has the functionality to make it an indispensable work partner. With a load width of 1,222mm between the wheel housings, the Amarok takes pallets with ease – shooting it right to the top of the dual cab ute class. Well positioned lashing eyes ensure that the load stays in place no matter what the terrain. And with around 250kg load bearing capability, the tough tailgate will take the brunt of the most demanding workloads.

**Rear bumper in black (not shown).** This robust bumper with a step tread is hard-wearing and reliable – the perfect no-nonsense finish to the back end of your Amarok.

T



**Tray capacity.** The Amarok accommodates a pallet between the wheel arches with well positioned lashing eyes as well.

A T H U



**Chrome-plated rear bumper.** This stylish rear bumper has an integrated step tread to make loading and unloading even easier. Good tread underfoot minimises slip – particularly useful if you’re moving heavy items.

H U



**Front bumper.** Particularly robust and durable, this unpainted bumper has a tough nylon coating to resist bumps and scratches.

A



**Front bumper – body-coloured.** Amarok Trendline comes with colour coded front bumper, door handles and mirror housings, and fog lights.

T



**Front bumper – chrome highlights.** Amarok Highline and Ultimate are enhanced with touches of chrome on the mirror housings and fog lights, the air intake and the radiator grille. There is also an underbody design element on the Ultimate model. (not shown).

H U

- standard
- Amarok
- Highline
- optional extra
- Trendline
- Ultimate



## Wheels.

Sturdy and powerful on open terrain, Volkswagen's range of alloy wheel options are suitable for any off-road challenge. Elegant on the esplanade, they make an impressive and classic statement everywhere they go. Amarok has a range of eye-catching wheels to choose from including the 16-inch steel wheels and the 16-inch "Taruma" alloy wheels. Then there are the 19-inch "Alastaro", 18-inch "Durban" and 17-inch "Aldo" alloy wheels, which all come with flared wheelhouses. No matter which look you prefer, you'll find the perfect set of alloy wheels in this impressive range.



**16-inch steel wheels.**  
With 205 R16 C 110/108T tyres.

**A**



**16-inch "Taruma" alloy wheels.**  
With 245/70 R16 111T tyres.

**A T**



**17-inch "Aldo" alloy wheels, including flared wheelhouses.** With 245/65 R17 111T tyres.



**18-inch "Durban" alloy wheels, including flared wheelhouses.**  
With 255/60 R18 112T tyres.

**H**



**19-inch "Alastaro" alloy wheels, including flared wheelhouses.**  
With 255/55 R19 111T tyres.

**U**

standard    **A** Amarok    **H** Highline  
 optional extra    **T** Trendline    **U** Ultimate

**A T**

## Safety.

With a variety of smart safety and handling systems on board, Amarok has earned its 5 Star ANCAP rating, awarded for the first time on a Dual Cab ute in Australia, and is capable of keeping passengers comfortable and secure on all kinds of terrain. The very latest safety technology combines with an engineering integrity that is typically Volkswagen – fastidious to the micro millimetre. In terms of handling, ABS and a new generation of ESP with Hill Start Assist and Hill Descent Assist provide the driver with control in all situations. An Off-road mode engages specific vehicle settings to help keep you safe when driving on loose surfaces. Beyond technology, the robust ladder frame brings great stability to the Amarok making it the ideal vehicle for day-to-day work – whether that be out on the road, out on the property, or on the worksite.



**Airbag technology** is an important part of every Amarok. Just milliseconds after the crash sensors register an impact, the driver's airbag and the front passenger airbag are inflated with a gas mixture to protect the head and upper body area. Combined head/thorax airbags are integrated in the sides of the front seats and are immediately activated following a side collision.



**Hill Start and Hill Descent Assist** are standard on all Amarok models. They prevent the Amarok from rolling backwards when starting on an uphill incline and apply braking pressure on downhill slopes. This technology assists drivers by alleviating the need for cumbersome handbrake starts, and helping control the vehicle on descents.

**Five 3-point safety belts and headrests** provide all passengers with optimum restraint and comfort.

**Anti-Slip Regulation (ASR)** activates a partial braking procedure, preventing wheelspin and providing for smooth acceleration. ASR is activated when one of the powered wheels has an unusually high rotation speed (slip rate).



**Electronic Stabilisation Programme (ESP)** helps prevent the vehicle from swerving. The system evaluates data provided by a network of sensors across the vehicle, which is interpreted to respond to critical driving conditions. It can even recognise a situation where the driver is steering in one direction and the vehicle is moving in another, while also taking into consideration the load on board. Armed with all this information, the system builds up brake force to offer directional stability where required. ESP is synchronised with the ABS, MSR and ASR functions and also remains activated with selectable 4MOTION all-wheel drive.



**Anti-lock Braking System (ABS)** really comes into its own when you're braking hard. To avoid skidding and losing the ability to steer, the system intervenes to allow the driver to brake and steer simultaneously and maintain control of the vehicle. Off-road ABS has been specifically developed for use on difficult terrain. As soon as the off-road ABS button is pressed, the braking interval is increased, and ESP and Hill Descent Assist are activated. The wheels lock up in a controlled manner so that small amounts of surface material (such as gravel or sand) build up in front of each wheel. This can substantially reduce the stopping distance of the vehicle.



**Electronic Differential Lock (EDL)** is particularly useful on slippery, uneven surfaces. For instance, if one wheel starts to spin, EDL locks that wheel and transfers all the power to the other powered wheels (the opposite back wheel on rear-wheel drive Amarok, and to the other three wheels on 4MOTION Amarok models). 4MOTION models come standard with an additional mechanical rear axle differential lock. When this rear differential lock is activated, both rear wheels receive the same amount of power and rotations. This offers optimal traction on sandy or slippery surfaces.

## 4MOTION.

The best way to experience intense ride comfort in the Amarok is by driving on rough terrain. Because that's where it can really prove what it has to offer: state-of-the-art gearbox technology, superior off-road capabilities and optimal traction. With Permanent 4MOTION drive with Torsen differential, you can make the most of the dynamic driving benefits of all-wheel drive. The system works well on bitumen roads and excels on open terrain. It is only available in conjunction with comfort leaf springs. The Selectable 4MOTION all-wheel drive option ensures reliable traction on all road surfaces. When 4MOTION is engaged, it distributes 50% of the engine output to each of the axles to improve forward thrust off-road. An additional low-range gear reduction setting can be engaged to cope with more rugged terrain or steep inclines. The Electronic Stabilisation Programme also functions when selectable 4MOTION is activated.



**Ramp angle.** The Amarok has excellent ground clearance to negotiate difficult terrain. With a ramp angle of 23°\*, large obstacles such as tree trunks and rocks are easier to negotiate.



**Approach and departure angle and wading depth.** The Amarok has an impressive approach angle of 28° and a departure angle of 23.6° (28° without bumper) as well as a wading depth of up to 500mm.



**Side slope angle.** The Amarok can traverse roads with a lateral tilt of approximately 49.7°<sup>1</sup>.



**Hill-climbing ability.** The Amarok can climb steep hills and carry your load at the same time. For instance, a 12% incline is handled easily while towing up to 2.8t, and with a 1 tonne payload, Amarok can conquer hills with a 45° incline.

**Heavy duty leaf springs** allow a payload of more than one tonne<sup>1</sup> and provide a high level of load safety. Heavy duty leaf springs are standard on all models.

**Comfort leaf springs** are perfect for those who require a payload of up to 850kg<sup>1</sup> but want the vehicle response of a passenger car. These leaf springs significantly increase driving comfort, especially at higher speeds, at the same time minimising noise levels. Comfort leaf springs are optional on all models.

\* Figures may vary depending on the equipment line and engine type. Please note that these are statically calculated figures. Please contact your local Volkswagen dealer for details of the standard equipment and optional extras applicable.



## Amarok powertrain.

Although Amarok is best experienced on rough terrain, that doesn't mean to say you won't be impressed by the smooth, comfortable driving characteristics on the bitumen. Either way, whether on sealed or unsealed, through water or snow, in mud or dust, or up a long steep hill, the Amarok will get you and your load to your destination quickly and safely. The powerful TDI340 single turbo and TDI400 Bi-turbo common rail diesel engines are among the most efficient of our time, achieving Euro 5 emission

standards and outstanding fuel efficiencies of between 7.7 and 7.9l/100km (depending on model). They're great figures and give you a potential range of more than 1,000km from a single tank. The TDI340 intercooled turbo diesel, paired with a six-speed manual transmission, punches out an impressive 90kW of power and a maximum torque of 340Nm.

If you're after more power, opt for the TDI400 intercooled Bi-turbo paired

with a six-speed manual transmission. With 120kW of power and a maximum torque of 400Nm, you've got virtually any job covered.

## Engine specifications.

Engine	TDI340		TDI400	
Type	4 Cylinder, DOHC, 16 Valve		4 Cylinder, DOHC, 16 Valve	
Capacity, litres/cc	2.0 / 1,968		2.0 / 1,968	
Bore x Stroke / Compression ratio	81.0mm x 95.5mm / 16.5:1		81.0mm x 95.5mm / 16.5:1	
Maximum power, kW @ rpm	90 @ 3,750		120 @ 4,000	
Maximum Torque, Nm @ rpm	340 @ 1,750-2,250		400 @ 1,500-2,500	
Induction Type	Single turbocharger		Bi-turbochargers	
Fuel System	Common Rail Direct Injection		Common Rail Direct Injection	
Intercooled	Yes		Yes	
Emissions standard	Euro 5* with Diesel Particle Filter (DPF)		Euro 5* with Diesel Particle Filter (DPF)	
Fuel Type	Diesel		Diesel	
Fuel Tank Capacity	80 Litres		80 Litres	
Battery	480 Amp 95Ah		480 Amp 95Ah	
<b>Transmission</b>				
Transmission	6 Speed Manual		6 Speed Manual	
Driven wheels	Rear wheel drive		Rear wheel drive / Selectable 4MOTION / Permanent 4MOTION (Ultimate)	
<b>Wheels and Tyres</b>	<b>Amarok</b>	<b>Amarok Trendline</b>	<b>Amarok Highline</b>	<b>Amarok Ultimate</b>
Wheels	Steel 6.5J x 16	Alloy "Taruma" 6.5J x 16	Alloy "Durban" 7.5J x 18	Alloy "Alastaro" 8.0J x 19
Tyres	205 R16 C 110/108T	245 / 70 R16 111T	255 / 60 R18 112T	255 / 55 R19 111T
<b>Fuel Consumption – ADR81/02</b>	<b>Comb / Urban / Ex Urban • CO<sub>2</sub></b>			
2WD, Litre/100km • CO <sub>2</sub>	7.7 / 9.5 / 6.8 • 203g/km			
Selectable 4MOTION, Litre/100km • CO <sub>2</sub>	7.9 / 9.7 / 7.0 • 209g/km			
Permanent 4MOTION, Litre/100km • CO <sub>2</sub>	7.9 / 9.7 / 7.0 • 209g/km			

\* Emission level according to European Regulation (EC) No. 715/2007 and Regulation (EC) No. 692/2008. The information and the specifications contained within this document were correct at the time of issue. Due to our continuous process of improvement our products are continually updated and changes may be made to the specifications from time to time. Not all vehicles or options may be available. Check at time of ordering.

## Dimensions.

Dimensions	TDI 340	TDI 400
Length, mm	5,181 (Amarok)	5,254 (Trendline, Highline and Ultimate)
Width, mm	1,944 (2,228 including mirrors)	1,944 (2,228 including mirrors)
Height std	1,834	1,834
Wheelbase, mm	3,095	3,095
Ground clearance mm	230 (192 with 4MOTION underbody protection)	230 (192 with 4MOTION underbody protection)
	Amarok	Amarok Trendline, Highline and Ultimate
Entry angle	28°	28°
Departure angle	28°	23.6°
Ramp angle	23° (21.4° with 4MOTION)	23° (21.4° with 4MOTION)
Wadding depth	500mm	500mm
	Cargo Area	
Rear tailgate width, mm	1,364	1,364
Rear tailgate height, mm	508	508
Load volume, m <sup>2</sup>	2.52	2.52
Length, mm	1,555	1,555
Width at widest point, mm	1,620	1,620
Width at wheel arch, mm	1,222	1,222
Height from ground, mm	780	780
	Warranty	
Vehicle	3 Years, Unlimited km	3 Years, Unlimited km
Paint / Corrosion	3 Years / 6 Years	3 Years / 6 Years
Road side assistance	3 Years, Unlimited km	3 Years, Unlimited km

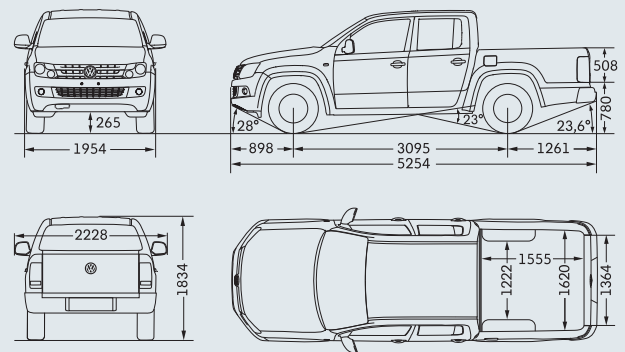
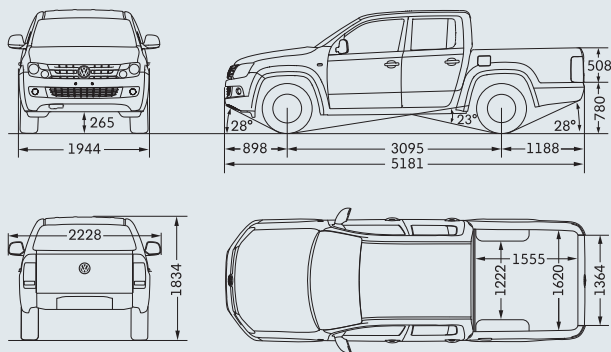

### Amarok

### Amarok – Trendline, Highline and Ultimate \*

\* Stainless steel side steps and stainless steel sports bar dimensions on Ultimate not pictured.



## Weights.

Weights				
GVM, kg	3,040 (optional 2,820)			
Towing capacity, braked / unbraked	2,800kg / 750kg			
Towing downball load	280kg			
Wheels and Tyres	Amarok	Amarok Trendline	Amarok Highline	Amarok Ultimate
GVM 3,040	Standard (Heavy Duty)*	Standard (Heavy Duty)*	Standard (Heavy Duty)*	Standard (Heavy Duty)*
GVM 2,820	Optional (Comfort Suspension)	Optional (Comfort Suspension)	Optional (Comfort Suspension)	Optional (Comfort Suspension)
Tare weight	1,883	2,042	2,069	2,110
Roof load, kg	100	100	100	100

## Suspension and brakes specifications.

Suspension & Steering	
Front axle	Transverse link with A-frame arm double wishbone and anti-roll bar
Rear axle	Multilayer rigid axle with leaf spring and stabiliser bar
Steering	Rack and pinion power steering
Turning Circle	12.95 m
Brakes	
Front brakes	303mm Disc brakes
Rear brakes	292mm Drum brake
Brake systems	ESP, Off-road ABS, ASR, EDL and Hill Holder

\* Not available with Permanent 4MOTION, Permanent 4MOTION only available with 2,820 GVM.

## Specifications and options.

Safety and Security	Amarok	Amarok Trendline	Amarok Highline	Amarok Ultimate
Drivers and front passenger airbag	S	S	S	S
Front side and thorax airbag	S	S	S	S
Electronic Stability Programme (ESP) with Brake Assist	S	S	S	S
Off-road ABS/ASR and EDL	S	S	S	S
Electronic engine immobiliser	S	S	S	S
Remote central locking	S	S	S	S
Front height adjustable 3-point seat belt with pre-tensioners	S	S	S	S
Park distance control – rear	–	–	O	S
Alarm with back-up horn	–	–	S	S
Seat belt warning (Driver's seat only)	S	S	S	S
<b>Exterior</b>				
Metallic paint	O	O	O	O
Pearl effect paint	O	O	O	O
Stainless steel sports bar	A	A	A	S
Stainless steel side steps	A	A	A	S
Underbody Design Element – Front	–	–	–	S
Front fog lights	–	S	S	S
High level brake light and cargo area lighting	S	S	S	S
Electrically adjustable door mirrors with heating function	S	S	S	S
Front and rear mud flaps	S	S	S	S
Heat insulating (Green) glass	S	S	S	S
Privacy glass (rear)	–	–	S	S
Engine and transmission protection – 4WD Models	S	S	S	S
Engine and transmission protection – 2WD Models	O	–	–	–
180° opening tailgate	S	–	–	–
Rear bumper with integrated step	–	S	S	S
Body coloured bumpers and mirror housings	–	S	–	–
Body coloured bumpers with chrome details and mirror covers	–	–	S	S
Tiedown points in cargo area (4)	S	S	S	S
16" x 6.5J Steel Wheels with 205 R16C 110/108T	S	–	–	–
16" x 6.5J Alloy wheels "Taruma" with 245/70 R16 111T tyres	O	S	–	–
17" x 8.0J Alloy wheels "Aldo" with 245/65 R17 111T tyres	O	O	–	–
18" x 7.5J Alloy wheels "Durban" with 255/60 R18 112T tyres	–	–	S	–
19" x 8.0 Alloy wheels "Alastaro" with 255/55 R19 111T tyres	–	–	–	S
Extended wheel arches (with 17", 18" or 19" Alloy Wheels)	O	O	S	S
Ladder Frame Chassis in high strength steel	S	S	S	S
<b>Interior</b>				
RCD310 Radio CD Player with MP3 Double Din with 2 speakers	S	–	–	–
RCD310 Radio CD Player with MP3 Double Din with 4 speakers	–	S	–	–
RCD510 Radio CD Player with MP3 Double Din with 6 speakers	–	–	S	S
Climatic air-conditioning	S	S	–	–
Climatronic air-conditioning dual-zone	–	–	S	S
Interior trim – "Spacer"	S	–	–	–
Interior trim – "Trail"	–	S	–	–
Interior trim – "Endless" Anthracite cloth	–	–	S	–
Interior trim – "Endless" Mendoza cloth	–	–	O	–
Interior trim – "Endless" Anthracite Leather	–	–	–	S
Interior trim – Vienna Mendoza Leather	–	–	–	O



## Specifications and options.

Interior (cont)	Amarok	Amarok Trendline	Amarok Highline	Amarok Ultimate
Interior light (door operated)	S	S	S	S
Interior light in rear	–	S	S	S
Map lights	–	S	S	S
Rubber floor covering in cab	S	–	–	–
Carpet floor covering in cab	–	S	S	S
Drawers under front seats	–	S	S	S
3 Child restraint location points	S	S	S	S
Centre console with cover and armrest	S	S	S	S
Leather gearshift knob and handbrake lever	–	–	S	S
Folding rear bench seat – backrest forwards and seat base upward with fastening strap	S	S	S	S
Headrests for rear bench seats (3)	S	S	S	S
Locking glove compartment	S	S	S	S
3 spoke steering wheel	S	S	S	S
Leather steering wheel	–	–	S	S
Multifunctional display	O	S	S	S
1 x 12V socket – centre console	S	–	–	–
3 x 12V sockets – dashboard, centre console and in cargo area	–	S	S	S
Driver and front passenger seat with height adjustment	S	S	S	S
Cloth seats	S	S	S	–
Leather trim	–	–	–	S
Interior grab handles Roof line/A-pillar/B-pillar	4/1	4/2/2	4/2/2	4/2/2
<b>Convenience</b>				
Front electric windows with roll-back function	S	S	S	S
Driver and passenger with one-touch up/down	S	S	S	S
Cruise control with multifunction display	O	S	S	S
<b>Instrumentation</b>				
Speedometer and tachometer, electronic odometer and trip meter, digital clock, fuel & coolant indicators, low fuel warning light and fuel gauge.	S	S	S	S
Multifunction display showing digital speed reading, range to empty, instant litres/100km and average litres/100km plus outside temperature.	O	S	S	S
<b>Mechanical</b>				
Electronic differential lock	S	S	S	S
Mechanical rear differential lock	O	S	S	S
2WD Transmission	S	–	–	–
Selectable 4MOTION Transmission	O	S	S	S
Permanent 4MOTION Transmission	–	–	–	O

S = Standard – = Not Available O = Optional A = Accessory

The information and the specifications contained within this document were correct at the time of issue. Due to our continuous process of improvement, our products are continually updated and changes may be made to the specifications from time to time. Not all vehicles or options may be available. Check at time of ordering.

## Accessories.



**Underbody design element.** This genuine underbody design element is perfect for adding a modest finishing touch to your Amarok. It discreetly creates a sleeker, smooth looking body without drastically changing the shaping of your vehicle.



**Sports bar – Stainless steel.** For that classic sporty look, you can't go past the Volkswagen Genuine Accessory Amarok sports bar in stainless steel. Sleek and stylish, this sports bar looks fantastic.



**Sports bar – Black.** Do you want to really stand out? This genuine Volkswagen Genuine Accessory Amarok sports bar in black will make a striking addition to your Amarok.



**Rear cabin grid.** On and off the road, you never know when you will need to brake suddenly. The Amarok rear cabin grid provides protection for passengers in the cabin if you do brake suddenly and your load becomes loose.



**Side tubes.** Details make all the difference and these tailored side tubes are the perfect way to create a truly streamlined look for your Amarok.



**Side steps.** Owning a vehicle is something very personal. And it's great to be able to make it feel like it's yours. You can really personalise your Amarok with these fantastic looking side steps available in black or silver.



**Amarok decorative.** If you're looking for a subtle, smart looking way to accessorise your Amarok, these genuine decorative panels with motif will add that eye catching touch without changing the overall shape of your vehicle.



**Soft tonneau cover.** While on the road you're at the mercy of the harsh Australian climate. This Volkswagen Genuine Accessory Amarok soft tonneau cover offers protection from the elements while ensuring you can access your load with ease.



**Hard tonneau cover.** No matter what you need to carry, this streamlined hard tonneau cover will protect your workload from a tough climate, while providing excellent security for complete peace of mind.

Images are for illustration purposes only. Overseas specification vehicles are shown.





**Carpet floor mats.** These carpet floor mats with Amarok motif are suitable for both driver and passenger sides and offer excellent protection from wear and tear, and give a luxurious look and feel to the cabin.



**Rubber floor mats.** These rubber floor mats with Amarok motif are suitable for both driver and passenger sides and do an excellent job of protecting the floor from wear and tear and dirty work boots.



**MEDIA-IN and connector cables.** Allows you to connect external audio sources including USB, USB mini, 3.5mm jack and iPod. Plays your favourite tracks through the vehicles audio system.



**Gear box protection.** Rough terrain is where Amarok really shines but that often means unsealed roads, ridden with debris. The gearbox protection system shields this state-of-the-art technology from a harsh off-road environment.



**Towbar.** The Amarok can handle a tough load but for times when you do want to tow a trailer, these genuine towbars have a 2800kg braked towing capacity and 750kg unbraked with a 280kg downball weight.



**19-inch ARAGONIT Alloy Wheel.** These wheels are designed to turn heads. The striking 19-inch Aragonit alloy wheels are robust and elegant, the ultimate way to make an impression.



**RNS510 Satellite Navigation System** is Volkswagen's state-of-the-art innovation, with a touch sensitive display for easy operation. High-res 16.9 screen and high performance processor, this system will calculate your travel routes at incredible speeds.



**Bluetooth Phone Kit.** Negotiating around busy roads and taking calls on the fly is now much easier thanks to this handy Bluetooth Touch Phone kit. It pairs with all major phones and installs neatly on the dash.



**16-inch AMAZONIT Alloy Wheel.** There is no denying the Amarok's good looks, but if you are looking to dress your vehicle up that little bit more, then these superb 16-inch alloy wheels are ideal.



## Paint colours.



Candy White  
Solid paint  
B4B4

A  T  H  U



Ontario Green  
Solid paint  
V7V7

A  T  H  U



Reflex Silver\*  
Metallic paint  
8E8E

A  T  H  U



Sand Beige\*  
Metallic paint  
P8P8

A  T  H  U



Starlight Blue\*  
Metallic paint  
3S3S

A  T  H  U



Natural Grey\*  
Metallic paint  
M4M4

A  T  H  U



Deep Black\*  
Pearl effect paint  
2T2T

A  T  H  U



Mendoza Brown\*  
Metallic paint  
7W7W

A  T  H  U

\*Metallic paint and pearl effect paint is available at extra cost. The illustrations on these pages can only be regarded as a general guide as the printing process cannot render the colours with absolute accuracy. Please contact your local Volkswagen dealer for details of the standard equipment and optional extras available.

standard

A Amarok

H Highline

optional extra

T Trendline

U Ultimate



# Trim.

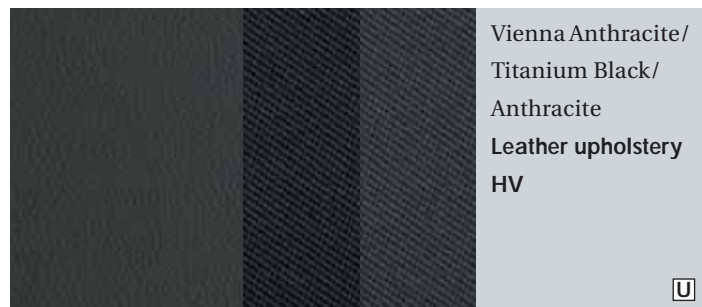
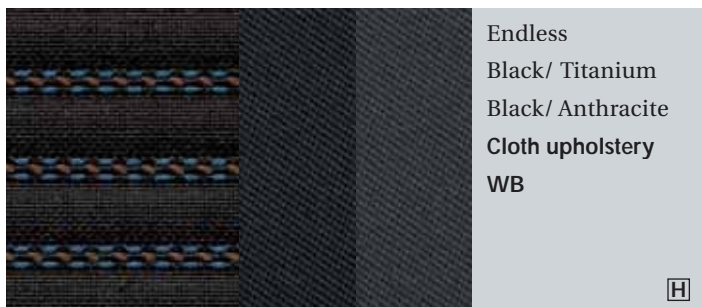
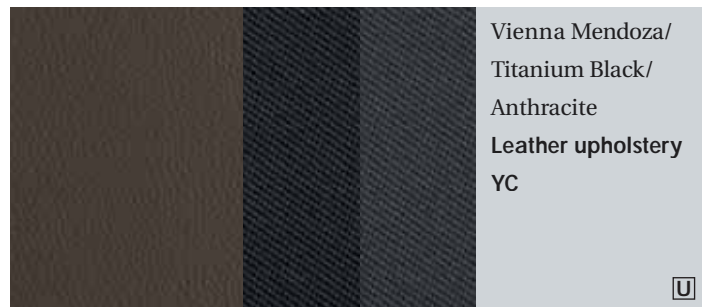
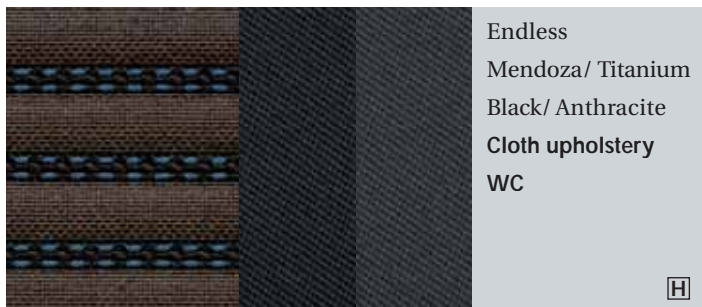
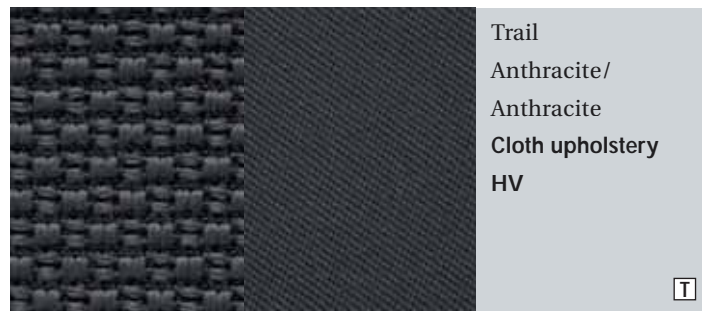
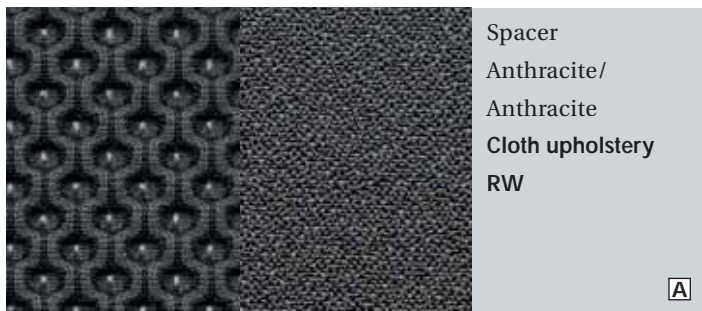

standard  
 optional extra

**A** Amarok  
**T** Trendline

**H** Highline  
**U** Ultimate

## Owning a Volkswagen.

### **Volkswagen New Vehicle Warranty**

Volkswagen Amarok is covered by a 3-year/unlimited kilometre manufacturer's warranty, which includes Volkswagen Assist (24hr roadside assistance). Amarok is also covered by a 3-year paintwork and 6-year anti-corrosion perforation warranty.

### **Volkswagen Assist**

#### **24 hour roadside assistance**

As a valued customer, you can be assured that, wherever you travel within Australia, you will have access to roadside assistance, 24 hours a day, 365 days a year. This is complimentary for the duration of the vehicle's original Volkswagen warranty period. You will receive help in the event of a breakdown

or accident and, if required, your vehicle will be mobilised or transported to an Authorised Volkswagen Repair Centre.

### **Volkswagen Extended Warranty**

Why not continue the confidence of a Volkswagen Warranty by purchasing a Volkswagen Extended Warranty? For further details on this option, please contact your local Volkswagen Dealer.

### **Volkswagen Service**

Your Authorised Volkswagen Service Centre is part of Volkswagen's global Quality Management System, ensuring all dealers are certified to ISO 9001:2000 – an internationally recognised Quality Standard. Authorised Volkswagen Service Centres have factory trained technicians equipped with the very

latest diagnostic equipment, specialist tooling and Volkswagen Genuine Parts. An Authorised Volkswagen Service Centre undertakes work in accordance with factory specified guidelines and maintenance schedules.

### **Volkswagen Genuine Parts®**

Volkswagen Genuine Parts® are designed for your vehicle and approved by Volkswagen, with particular regard to safety. The workmanship, dimensional accuracy and materials used in these parts comply with factory specifications. To ensure safety and reliability, Volkswagen recommends the use of Volkswagen Genuine Parts®. Volkswagen Authorised Dealers offer a 2-year warranty on Genuine Parts from the date of purchase.

## Environment.

At Volkswagen, we don't see the word 'Environment' as a barrier. We believe that sound environmental sustainability offers the opportunity to develop long-term innovations, including new approaches, efficient technologies and ground-breaking products. An internal Environment Committee was established in order to manage our business activities from an environmental point of view and to find solutions to reduce our environmental impact.

As a first and important step, Volkswagen Group Australia have developed a

Carbon Management Strategy helping us to identify and manage our carbon emissions from our business activities. This has led to a Carbon Management Program throughout the organisation, empowered to recommend changes that mean real emissions reductions. From reduced electricity consumption to optimised business flights, we're making changes to reduce our carbon footprint.

On a local level, we have also undertaken a number of initiatives to reduce the environmental impact of our business processes, from office recycling to using

waterless urinals in bathrooms. Energy usage is being reduced through lights controlled by motion sensors in toilets, kitchens and meeting rooms.

But there's no question that the area in which we can contribute most to environmental sustainability is with our vehicles. Our TDI diesel engines consume less fuel and emit less exhaust fumes offering high torque and performance, while our diesel particulate filters extract soot from the exhaust fumes. Numerous engines already fulfill the very stringent Euro 5 norm.

## General Information.

Volkswagen is distributed by Volkswagen Group Australia Pty Ltd, The Lakes Business Park, 6 Lord St, Botany, NSW 2019. ABN 14 093 117 876. Specifications are as planned at March 2011 for model year 2011 and are subject to change without notice or obligation. Cars and accessories are shown for illustrative purposes only and may not depict Australian specifications. Fuel consumption figures according to Australian Design Rules (ADR) 81/02. All Volkswagen approved parts and accessories are warranted for 2 years/unlimited kilometres or new vehicle warranty. All warranties implied by legislation or otherwise are excluded to the maximum extent permitted by law. The liability of Volkswagen shall, subject to the law, be limited at Volkswagen's discretion: 1. In the case of the goods, the repair or the cost of repair, or the replacement or the cost of replacement; and 2. In the case of services, the re-supply of the services or the cost of re-supply of the services. All information in this brochure is correct at time of publication, however variations may occur from time to time and Volkswagen, in so far as it is permitted by law to do so, shall not be liable in any way as a result of any reliance by any person on anything contained in this brochure. The colours shown in the brochure are indicative only and may vary from actual items owing to the printing process. Authorised Volkswagen dealers will provide up-to-date information on model application, design feature, prices and availability on request. Volkswagen Insurance & Volkswagen Extended Warranty are provided by Allianz Australia Insurance Limited (Allianz), AFS Licence No. 234708, ABN 15 000 122 580. In arranging this insurance, Volkswagen Financial Services Australia Limited, ABN 20 097 071 460 & Volkswagen Group Australia Pty Ltd, ABN 14 093 117 896 and the authorised dealers act as agents of Allianz and not as your agent. Volkswagen Finance is a trading name of Volkswagen Financial Services Australia Limited. Locked Bag 5009, Alexandria NSW 2015. Tel: 02 9695 6311.



# The Amarok

March 2011

[www.volkswagen-commercial.com.au](http://www.volkswagen-commercial.com.au)