

**1.9 I/85 kW Turbo diesel engine with unit injectors, engine codes AJM**

from May 1999

**1.9 I/85 kW Turbo diesel engine with unit injectors, engine codes AUJ**

From July 2000

**1.9 I/74 kW Turbo diesel engine with unit injectors, engine codes ATD**

from September 2000

For alternatives to relay and fuse positions as well as multi-pin connector wiring - see "Fitting locations" section.

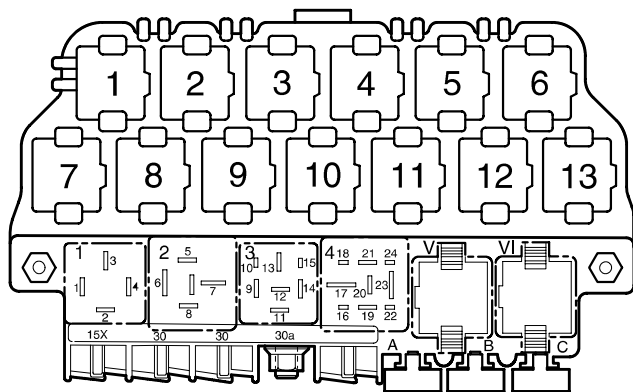

97-14163

**Relay locations on the 13 position additional relay carrier above the relay plate:**

- 10** Fuel pump relay (167)
- 12** Terminal 30 voltage supply relay (109)

**Relay locations on relay plate:**

- 2** X contact relief relay (100)
- 4** Glow plug relay (103)

**Fuse colours**

- 30 A - green
- 25 A - white
- 20 A - yellow
- 15 A - blue
- 10 A - red
- 7.5 A - brown
- 5 A - beige
- 3 A - purple

**Note:**

The number in brackets behind the part designation denotes the control number on the housing.

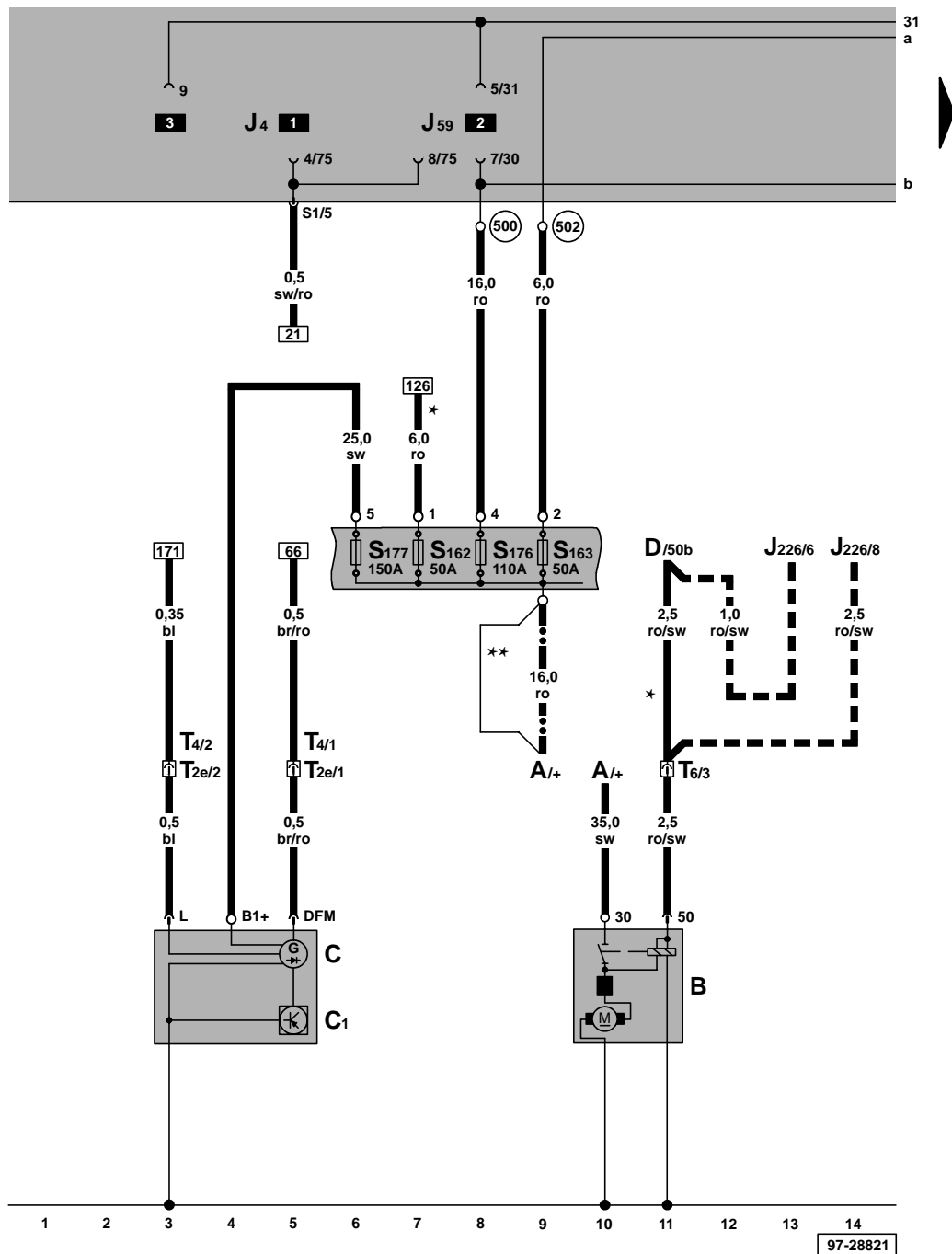

Alternator, starter

- A - Battery
- B - Starter
- C - Alternator
- C1 - Voltage regulator
- D - Ignition/starter switch
- J4 - Dual tone horn relay
- J59 - X contact relief relay
- J226 - Starter inhibitor and reversing light relay, on the 13 position additional relay carrier
- S162 - Fuse -1- (30), in fuse box/battery
- S163 - Fuse -2- (30), in fuse box/battery
- S176 - Fuse -4- (30), in fuse box/battery
- S177 - Fuse -5- (30), in fuse box/battery
- T2e - 2-pin connector, near starter (only models without air conditioner)
- T4 - 4-pin connector, near starter (only models with air conditioner)
- T6 - 6-pin connector, brown, in control unit protective housing, in plenum chamber, left

- (500) - Screw connection -1- (30), on relay plate
- (502) - Screw connection -1- (30a), on relay plate

- \* - Only models with manual gearbox
- From September 2000
- \*\* - Up to August 2000
- - - Only models with automatic gearbox

ws = white  
 sw = black  
 ro = red  
 br = brown  
 gn = green  
 bl = blue  
 gr = grey  
 li = purple  
 ge = yellow  
 or = orange

**Diesel direct injection system control unit, glow plugs - engine**

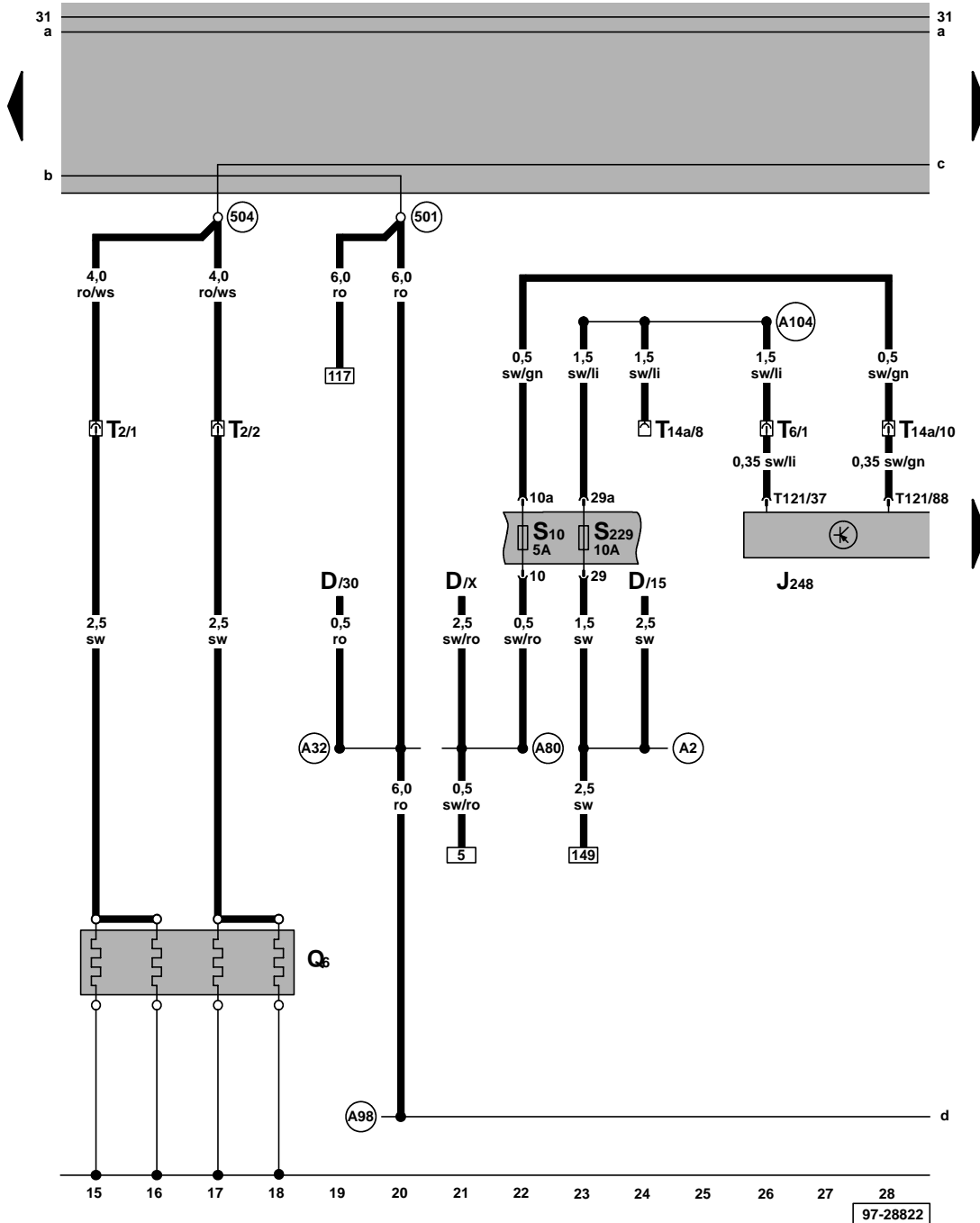

- D - Ignition/starter switch
- J248 - Diesel direct injection system control unit, in plenum chamber, centre
- Q6 - Glow plugs - engine
- S10 - Fuse in fuse box
- S229 - Fuse in fuse box
- T2 - 2-pin connector, in cable channel left in engine compartment
- T6 - 6-pin connector, brown, in control unit protective housing, in plenum chamber, left
- T14a - 14-pin connector, in cable channel left in engine compartment
- T121 - 121-pin connector

- (501) - Screw connection -2- (30), on relay plate
- (504) - Screw connection (87F), on relay plate
- (A2) - Positive (+) connection (15), in dash panel wiring harness
- (A32) - Positive (+) connection (30), in dash panel wiring harness
- (A80) - Connection -1- (X), in dash panel wiring harness
- (A98) - Positive (+) connection -4- (30), in dash panel wiring harness
- (A104) - Positive (+) connection -2- (15), in dash panel wiring harness

ws = white  
 sw = black  
 ro = red  
 br = brown  
 gn = green  
 bl = blue  
 gr = grey  
 li = lilac  
 ge = yellow  
 or = orange

Diesel direct injection system control unit, glow plug relay, kick-down switch, engine speed sender, idling switch, accelerator pedal position sender, terminal 30 voltage supply relay

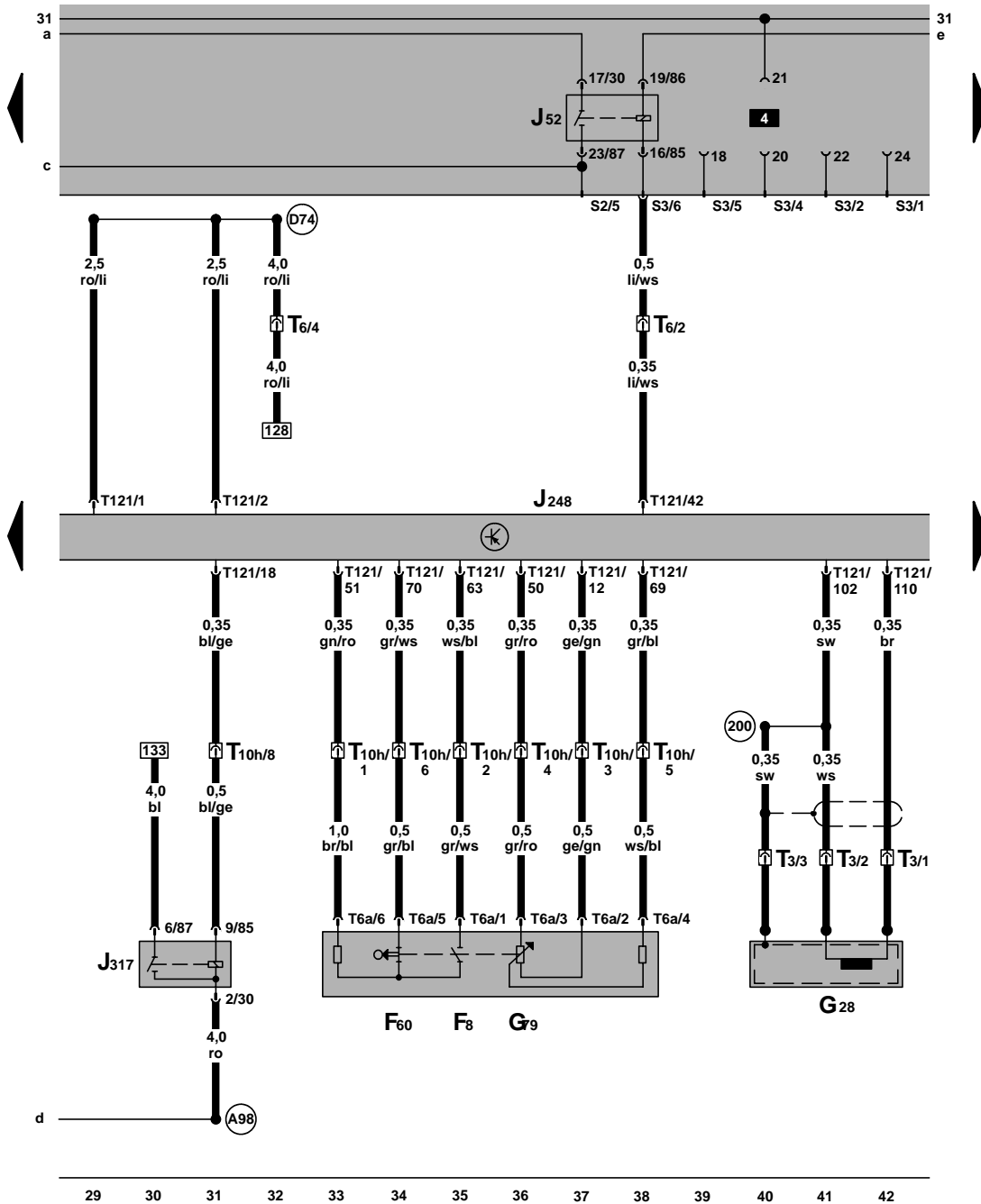

- F8 - Kick-down switch
- F60 - Idling switch
- G28 - Engine speed sender
- G79 - Accelerator pedal position sender
- J52 - Glow plug relay
- J248 - Diesel direct injection system control unit, in plenum chamber, centre
- J317 - Terminal 30 voltage supply relay, above the central electrics
- T3 - 3-pin connector, on engine front
- T6 - 6-pin connector, brown, in control unit protective housing, in plenum chamber, left
- T6a - 6-pin connector
- T10h - 10-pin connector, blue, in control unit protective housing, in plenum chamber, left
- T121 - 121-pin connector

- (200) - Earth connection (screening), in engine compartment wiring harness
- (A98) - Positive (+) connection -4- (30), in dash panel wiring harness
- (D74) - Connection (86), in engine compartment wiring harness

ws = white  
 sw = black  
 ro = red  
 br = brown  
 gn = green  
 bl = blue  
 gr = grey  
 li = lilac  
 ge = yellow  
 or = orange

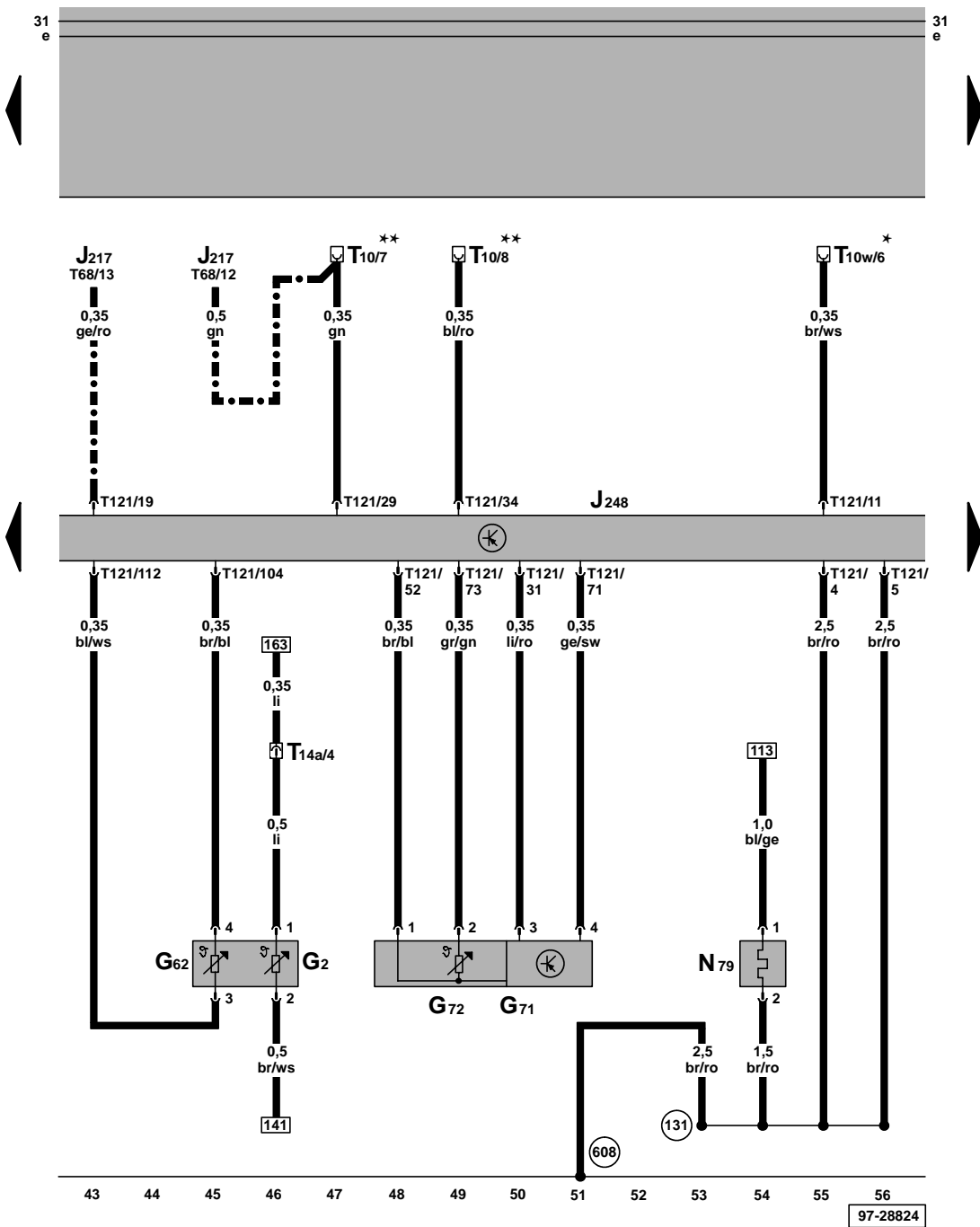

Diesel direct injection system control unit, coolant temperature sender, intake manifold pressure sender, intake manifold temperature sender, heater element (crankcase breather)

- G2 - Coolant temperature sender
- G62 - Coolant temperature sender
- G71 - Intake manifold pressure sender
- G72 - Intake manifold temperature sender
- J217 - Automatic gearbox control unit
- J248 - Diesel direct injection system control unit, in plenum chamber, centre
- N79 - Heater element (crankcase breather)
- T10 - 10-pin connector, orange, in protective housing for connectors, in plenum chamber, left
- T10w - 10-pin connector, white, in protective housing for connectors, in plenum chamber, left
- T14a - 14-pin connector, in cable channel left in engine compartment
- T68 - 68-pin connector
- T121 - 121-pin connector

- (131) - Earth connection -2-, in engine compartment wiring harness
- (608) - Earth point, in plenum chamber, centre

- \* - Radiator fan control unit/ radiator fan relay connection
- \*\* - Connection for air conditioner
- | - Only models with four speed automatic gearbox (AG4)

ws = white  
 sw = black  
 ro = red  
 br = brown  
 gn = green  
 bl = blue  
 gr = grey  
 li = lilac  
 ge = yellow  
 or = orange

Diesel direct injection system control unit

- J104 - ABS/ABS with EDL control unit
- J217 - Automatic gearbox control unit
- J248 - Diesel direct injection system control unit, in plenum chamber, centre
- T10 - 10-pin connector, orange, in protective housing for connectors, in plenum chamber, left
- T10w- 10-pin connector, white, in protective housing for connectors, in plenum chamber, left
- T25 - 25-pin connector, on ABS/ABS with EDL control unit
- T47 - 47-pin connector, ABS with EDL/TCS/ESP control unit (up to July 2000)
- T47a - 47-pin connector, ABS/ABS with EDL/TCS/ESP control unit (from August 2000)
- T68 - 68-pin connector, only models with four speed automatic gearbox (AG4)
- T68a - 68-pin connector, only models with five speed automatic gearbox (AG5)
- T121 - 121-pin connector

- (A121) - Connection (high bus), in dash panel wiring harness
- (A122) - Connection (low bus), in dash panel wiring harness

--- Only models with automatic gearbox

ws = white  
 sw = black  
 ro = red  
 br = brown  
 gn = green  
 bl = blue  
 gr = grey  
 li = lilac  
 ge = yellow  
 or = orange

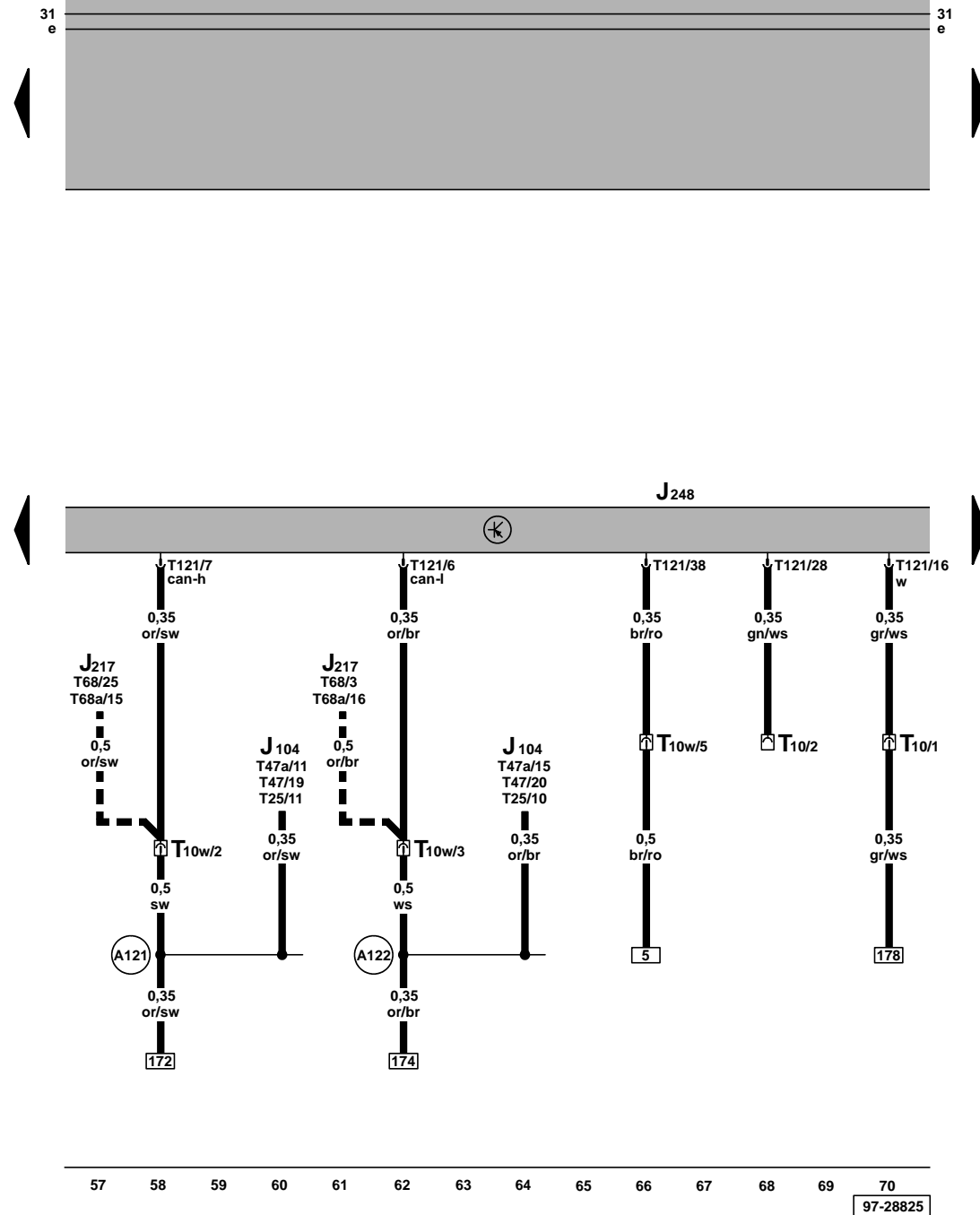

**Diesel direct injection system control unit, unit injector solenoid valves, hall sender (for camshaft position)**

- G40 - Hall sender (for camshaft position)
- J248 - Diesel direct injection system control unit, in plenum chamber, centre
- N240- Unit injector solenoid valve, No. 1 cyl.
- N241- Unit injector solenoid valve, No. 2 cyl.
- N242- Unit injector solenoid valve, No. 3 cyl.
- N243- Unit injector solenoid valve, No. 4 cyl.
- T3a - 3-pin connector, on engine front
- T8 - 8-pin connector, in engine compartment, left
- T121 - 121-pin connector

(D101) - Connection -1-, in engine compartment wiring harness

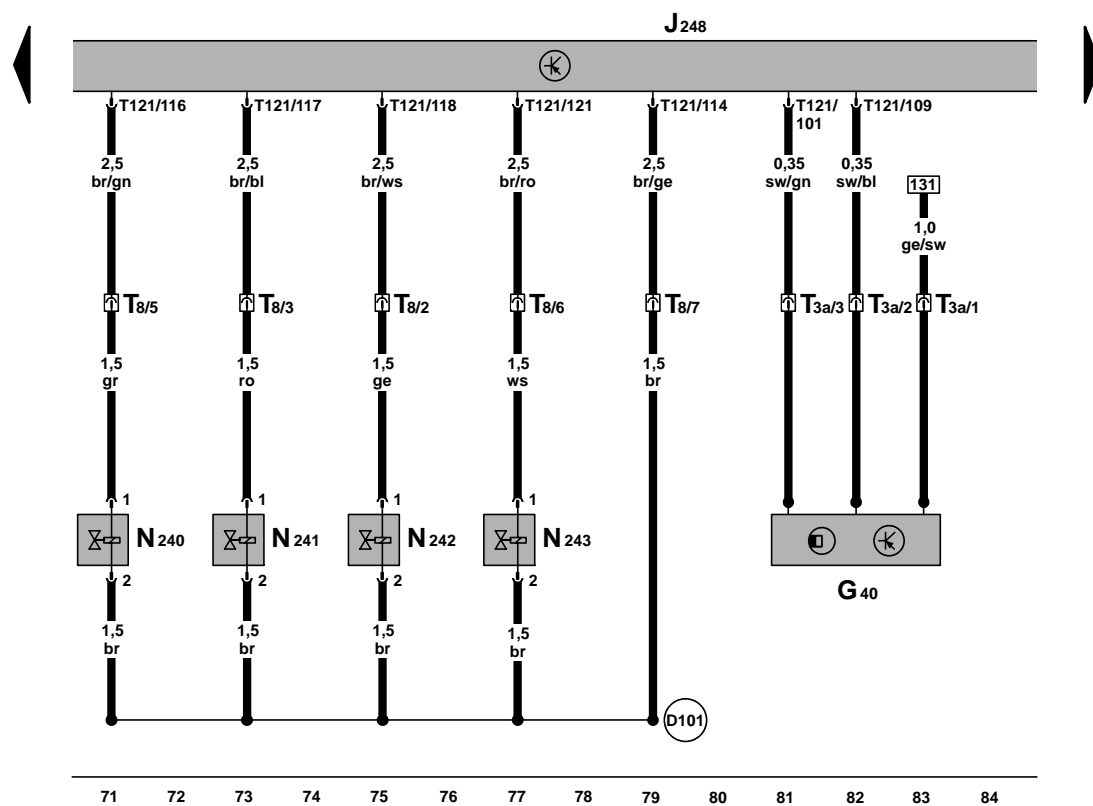
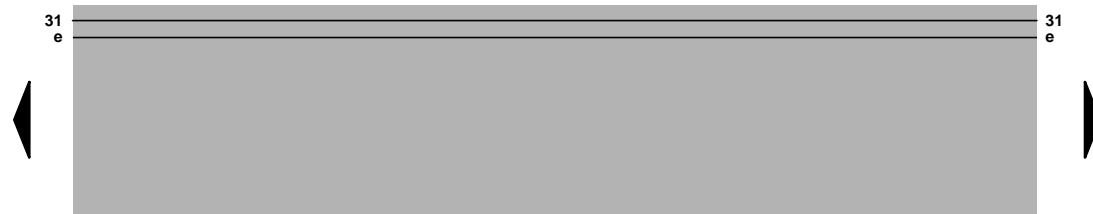

- ws = white
- sw = black
- ro = red
- br = brown
- gn = green
- bl = blue
- gr = grey
- li = lilac
- ge = yellow
- or = orange

71 72 73 74 75 76 77 78 79 80 81 82 83 84

97-28826

Diesel direct injection system control unit, air mass meter, intake manifold flap change-over valve, fuel temperature sender, exhaust gas recirculation valve, charge pressure control solenoid valve

- G70 - Air mass meter
- G81 - Fuel temperature sender
- J248 - Diesel direct injection system control unit, in plenum chamber, centre
- N18 - Exhaust gas recirculation valve
- N75 - Charge pressure control solenoid valve
- N239 - Intake manifold flap change-over valve
- T5 - 5-pin connector
- T10w - 10-pin connector, white, in protective housing for connectors, in plenum chamber, left
- T121 - 121-pin connector

(E29) - Connection, in engine wiring harness

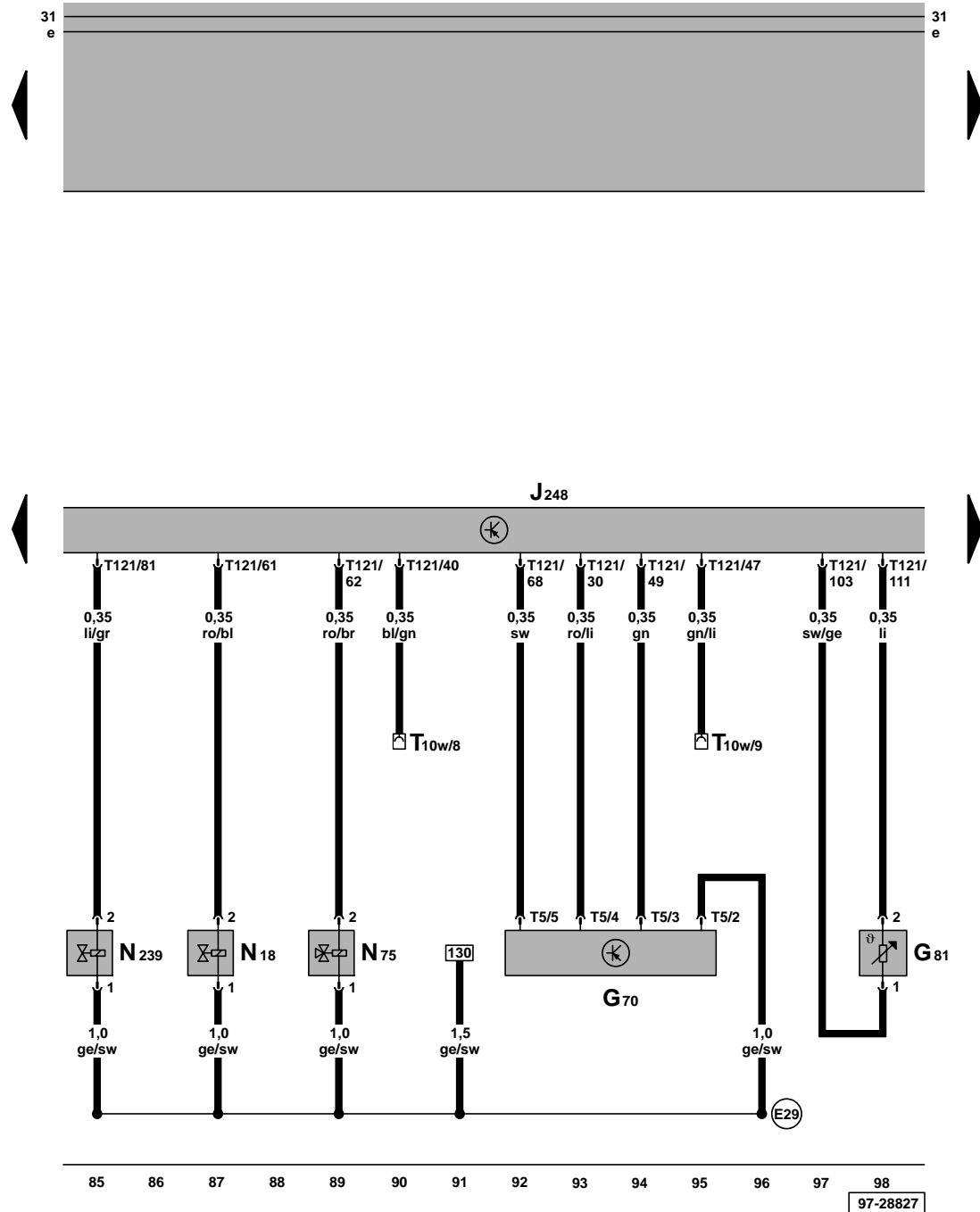



**Diesel direct injection system control unit, cruise control system switch (CCS), clutch pedal switch**

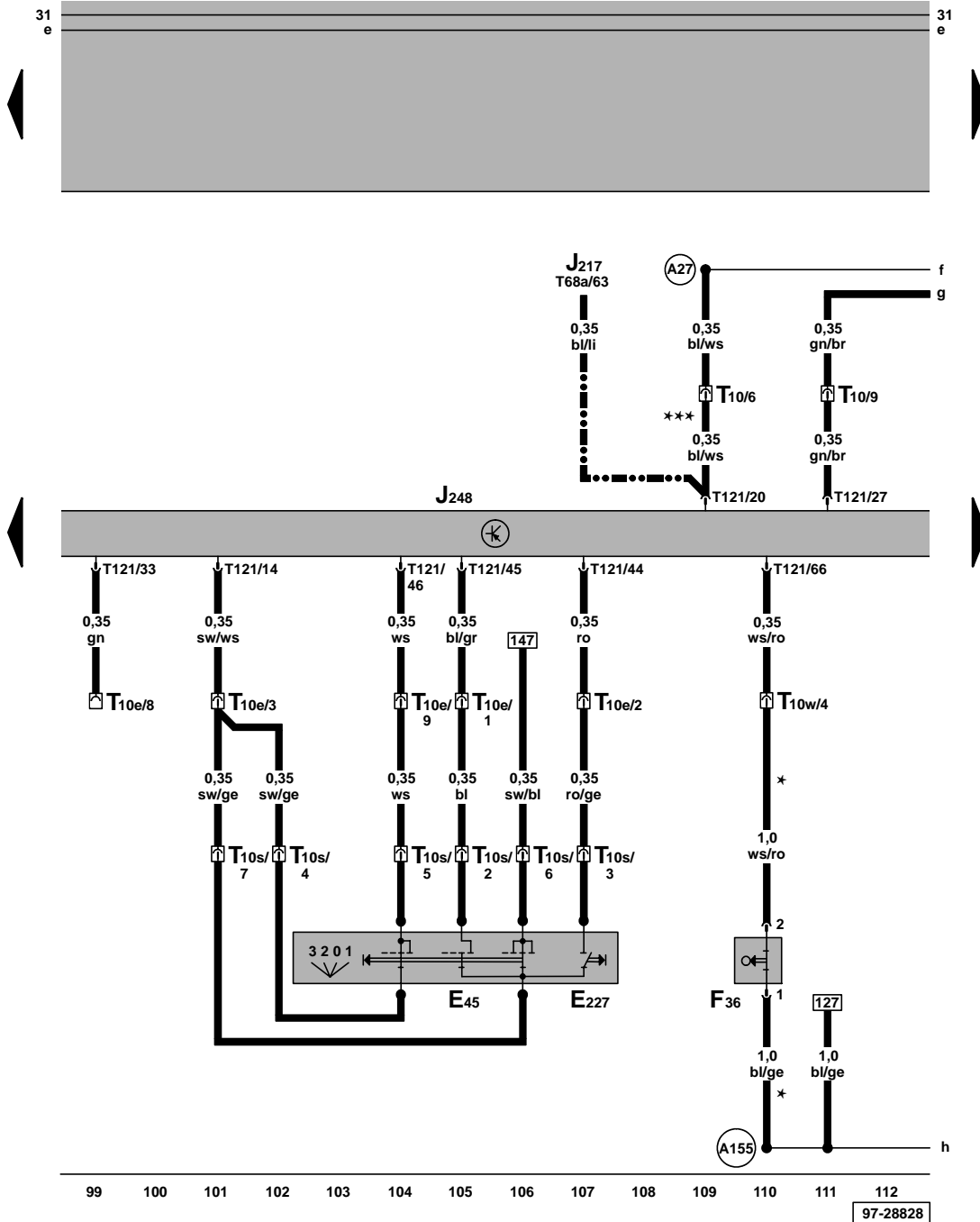

- E45 - Cruise control system switch\*\*
- E227 - Cruise control system (CCS) button (Set)\*\*
- F36 - Clutch pedal switch\*
- J217 - Automatic gearbox control unit
- J248 - Diesel direct injection system control unit, in plenum chamber, centre
- T10 - 10-pin connector, orange, in protective housing for connectors, in plenum chamber, left
- T10e - 10-pin connector, black, in control unit protective housing, in plenum chamber, left
- T10s - 10-pin connector, next to steering column
- T10w - 10-pin connector, white, in protective housing for connectors, in plenum chamber, left
- T68a - 68-pin connector
- T121 - 121-pin connector

- (A27) - Connection (speed signal), in dash panel wiring harness
- (A155) - Connection -2- (86), in dash panel wiring harness

- \* - Only models with manual gearbox
- \*\* - Only models with CCS
- \*\*\* - Only models with manual gearbox or four speed automatic gearbox (AG4)
- .- - Only models with five speed automatic gearbox (AG5)

ws = white  
 sw = black  
 ro = red  
 br = brown  
 gn = green  
 bl = blue  
 gr = grey  
 li = lilac  
 ge = yellow  
 or = orange

**Diesel direct injection system control unit, coolant heater element, cruise cont. sys. brake pedal switch (diesel direct inj. system), brake light switch, high and low heat output relay**

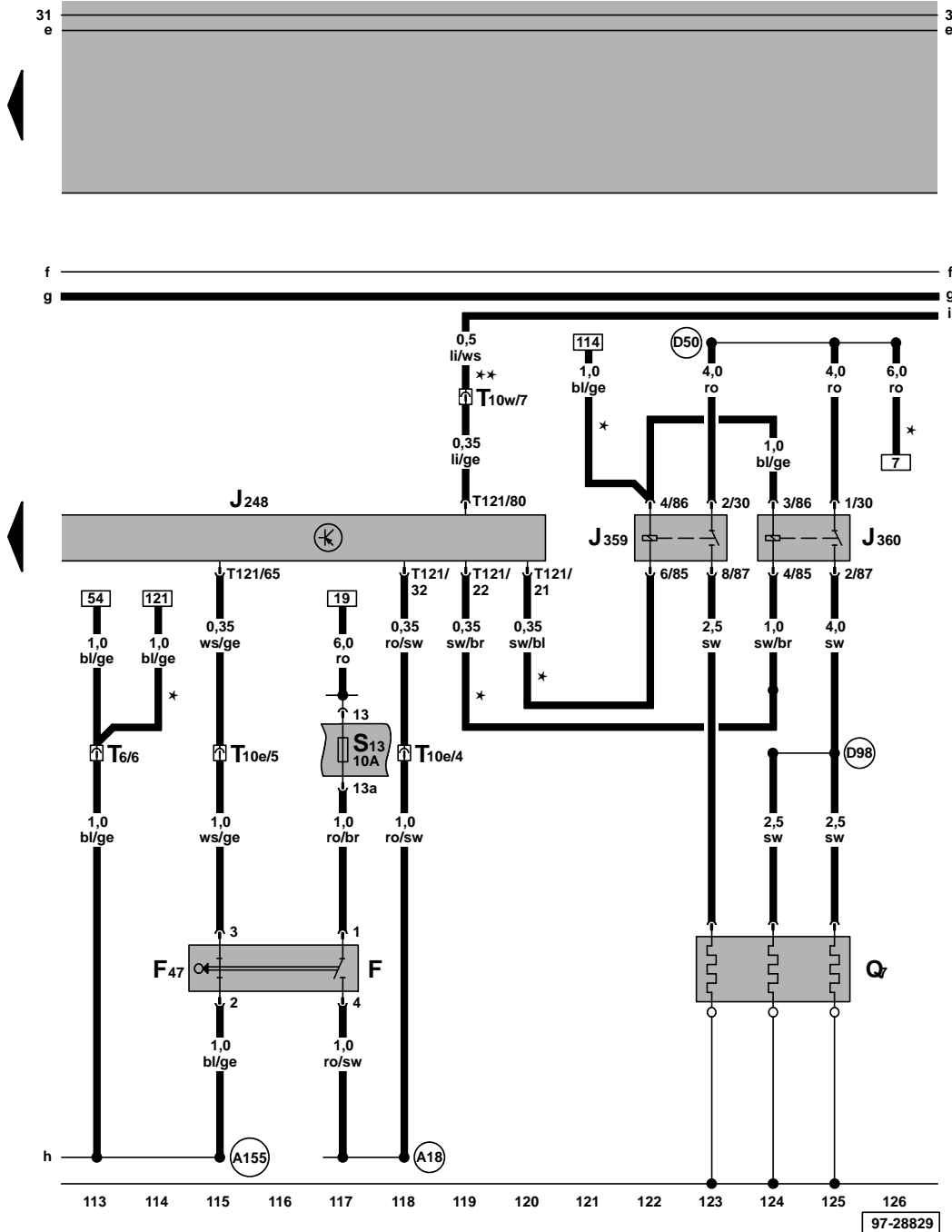

- F - Brake light switch
- F47 - Cruise control system brake pedal switch/diesel direct inj. system
- J248 - Diesel direct injection system control unit, in plenum chamber, centre
- J359 - Low heat output relay\*, in protective housing in engine compartment, left (53)
- J360 - High heat output relay\*, in protective housing in engine compartment, left (100)
- Q7 - Coolant heating elements\*
- S13 - Fuse in fuse box
- T6 - 6-pin connector, brown, in protective housing for connectors, in plenum chamber, left
- T10e - 10-pin connector, black, in protective housing for connectors, in plenum chamber, left
- T10w - 10-pin connector, white, in protective housing for connectors, in plenum chamber, left
- T121 - 121-pin connector

- (A18) - Connection (54), in dash panel wiring harness
- (A155) - Connection -2- (86), in dash panel wiring harness
- (D50) - Positive (+) connection (30), in engine compartment wiring harness
- (D98) - Connection (glow plugs), in engine compartment wiring harness

- \* - Only models with manual gearbox
- \*\* - from September 2000

ws = white  
 sw = black  
 ro = red  
 br = brown  
 gn = green  
 bl = blue  
 gr = grey  
 li = lilac  
 ge = yellow  
 or = orange

Fuel gauge sender, fuel pump relay, fuel pump (pre-supply pump)

- G - Fuel gauge sender\*\*\*
  - G6 - Fuel pump (pre-supply pump)
  - J17 - Fuel pump relay, on additional relay carrier above the relay plate
  - S228 - Fuse 28 in fuse box
  - S232 - Fuse 32 in fuse box
  - S234 - Fuse 34 in fuse box
  - S243 - Fuse 43 in fuse box
  - T6 - 6-pin connector, brown, in control unit protective housing, in plenum chamber, left
  - T14a - 14-pin connector, near battery
- (42) - Earth point, next to steering column
  - (81) - Earth connection -1-, in dash panel wiring harness
  - (269) - Earth connection (sender earth) -1-, in dash panel wiring harness
  - (A71) - Connection (86), in dash panel wiring harness
  - (A100) - Connection -2- (87), in dash panel wiring harness
  - (B168) - Connection (86), in interior wiring harness
- \* - From May 2000
  - \*\* - From September 2000
  - .- - Up to April 2000
  - Up to August 2000
  - \*\*\* - Only models with four-wheel drive ⇒ Current flow diagram four-wheel drive

ws = white  
 sw = black  
 ro = red  
 br = brown  
 gn = green  
 bl = blue  
 gr = grey  
 li = purple  
 ge = yellow  
 or = orange

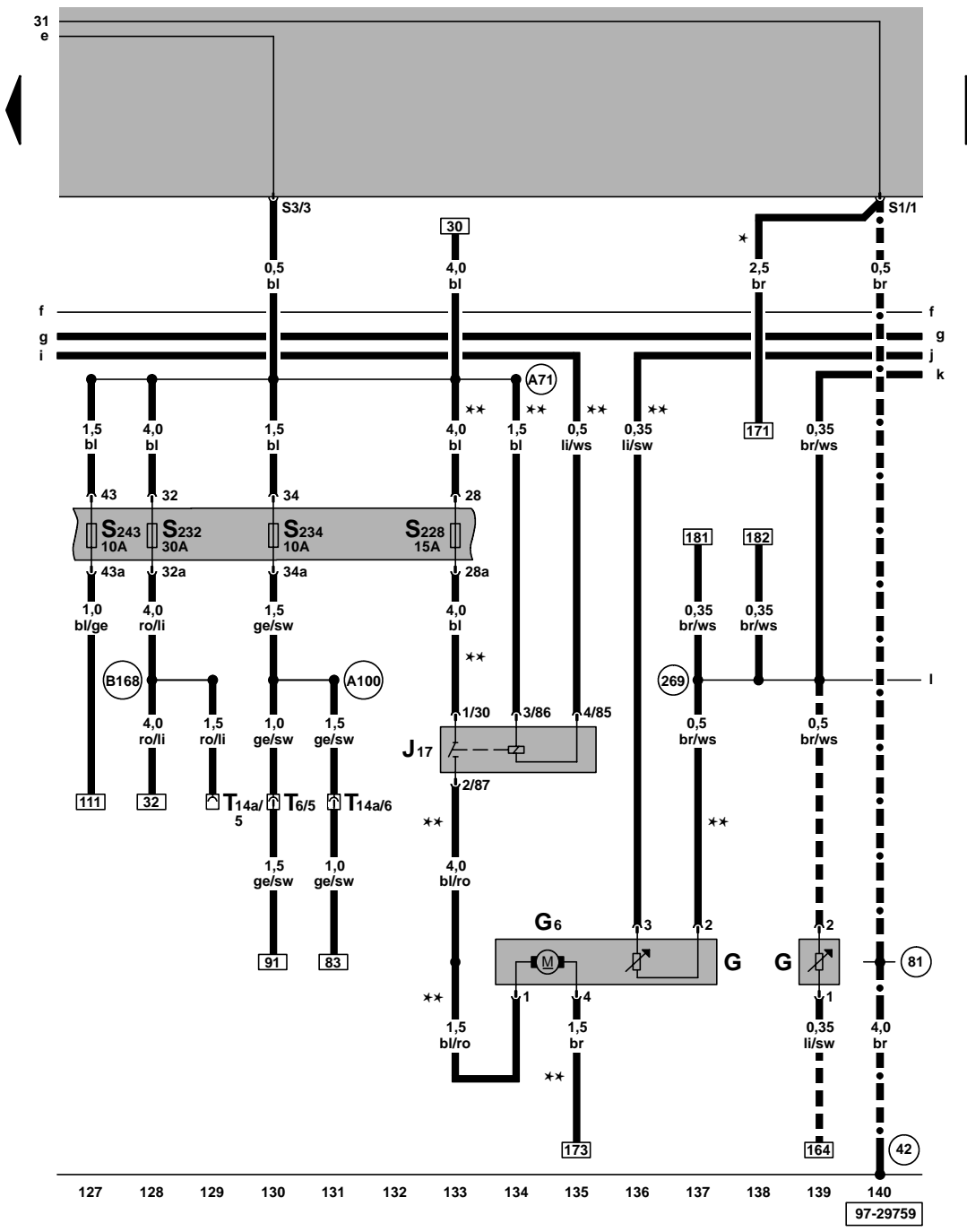

Oil level/oil temperature sender, oil pressure switch, speedometer sender, coolant shortage indicator sender

- F1 - Oil pressure switch
- G22 - Speedometer sender (hall sender, on gearbox)
- G32 - Coolant shortage indicator sender
- G266 - Oil level/oil temperature sender\*\*\*
- J217 - Automatic gearbox control unit
- S5 - Fuse in fuse box
- S7 - Fuse in fuse box
- T10h - 10-pin connector, blue, in control unit protective housing, in plenum chamber, left
- T14a - 14-pin connector, near battery
- T68a - 68-pin connector

- (85) - Earth connection -1-, in engine compartment wiring harness
- (269) - Earth connection (sender earth) -1-, in dash panel wiring harness
- (608) - Earth point, in plenum chamber, centre
- (A20) - Connection (15a), in dash panel wiring harness
- (B163) - Positive (+) connection -1- (15), in interior wiring harness

- \* - Only models with manual gearbox
- \*\*\* - Only with flexible service interval display
- - - Only models with automatic gearbox (AG4)
- . . - Only models with five speed automatic gearbox (AG5)

ws = white  
 sw = black  
 ro = red  
 br = brown  
 gn = green  
 bl = blue  
 gr = grey  
 li = purple  
 ge = yellow  
 or = orange

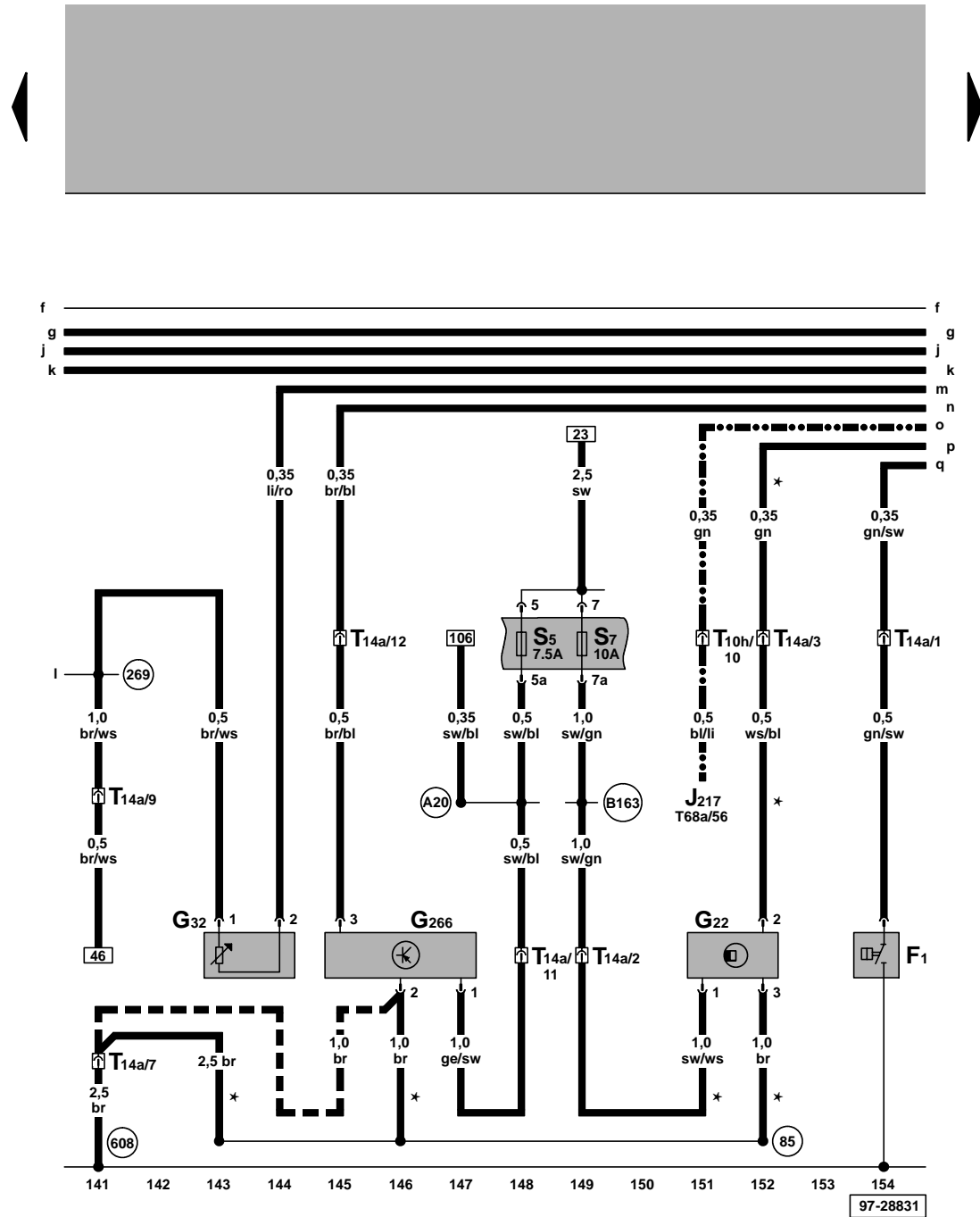

Dash panel insert, coolant temperature gauge and fuel gauge, fuel gauge, rev. counter, oil pressure warning lamp

- G1 - Fuel gauge
- G3 - Coolant temperature gauge
- G5 - Rev. counter
- J285 - Control unit with display in dash panel insert
- K3 - Oil pressure warning lamp
- K28 - Coolant temperature/coolant shortage warning lamp
- K38 - Oil level warning lamp\*\*\*
- K105 - Reserve fuel warning lamp
- T12a - 12-pin connector, connection for Climatronic only
- T32 - 32-pin connector, blue
- T32a - 32-pin connector, green

- \* - Only models with manual gearbox
- \*\* - From September 2000
- Up to August 2000
- \*\*\* - Only with flexible service interval display
- .-.- Only models with five speed automatic gearbox (AG5)

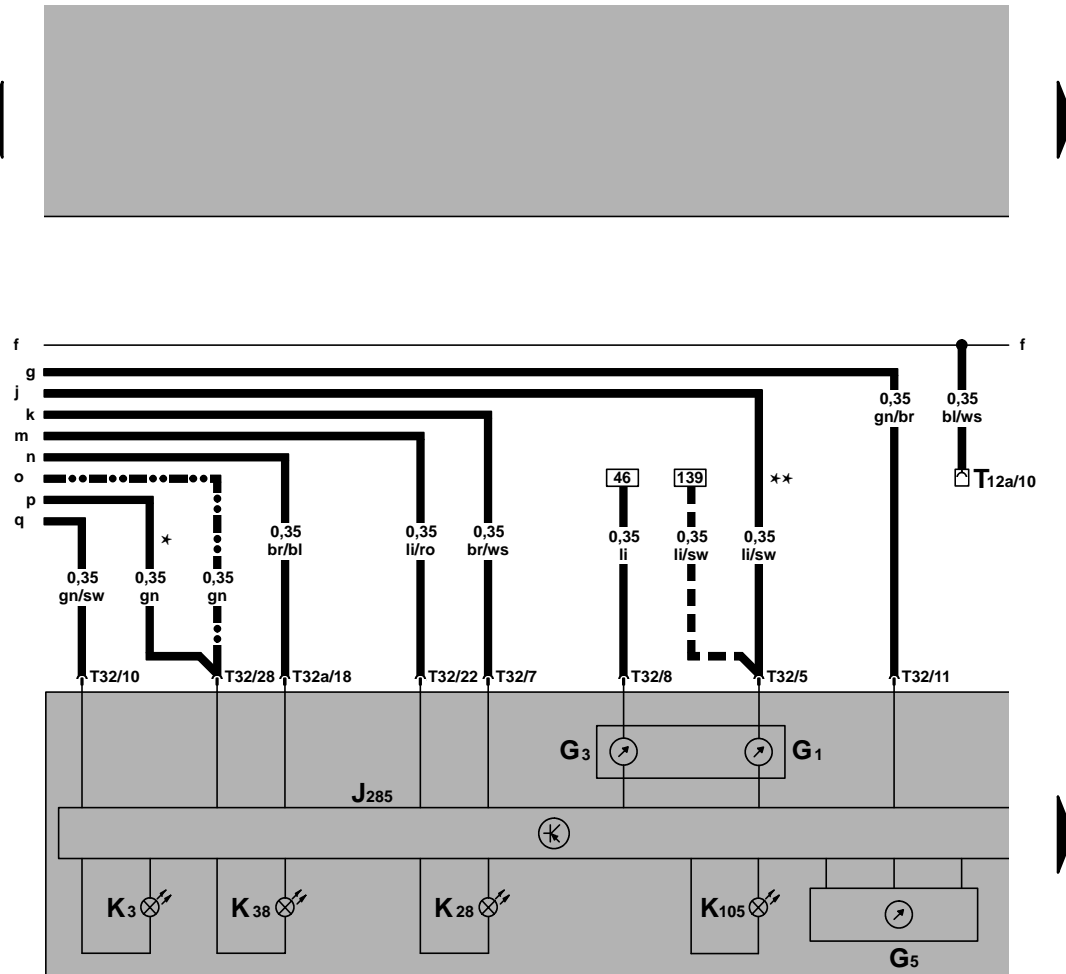

Dash panel insert, multi-function display, ambient temperature indicator, self-diagnosis connection, glow period warning lamp, cruise control system warning lamp, speedometer

- E86 - Multi-function display call-up button
- E109 - Multi-function display, memory switch
- G17 - Ambient temperature sensor
- G21 - Speedometer
- H3 - Warning buzzer
- J119 - Multi-function display
- J285 - Control unit with display in dash panel insert
- J533 - Data bus diagnostic interface, in dash panel insert
- K2 - Alternator warning lamp
- K29 - Glow period warning lamp
- K31 - Cruise control system warning lamp
- T6e - 6-pin connector
- T16 - 16-pin connector, in dash panel centre, self-diagnosis connection
- T32 - 32-pin connector, blue
- T32a - 32-pin connector, green

- (42) - Earth point, next to steering column
- (49) - Earth point, on steering column
- (135) - Earth connection -2-, in dash panel wiring harness
- (A27) - Connection (speed signal), in dash panel wiring harness
- (A76) - Connection (diagnosis wire K), in dash panel wiring harness

- \* - From May 2000
- \*\* - From September 2000

ws = white  
 sw = black  
 ro = red  
 br = brown  
 gn = green  
 bl = blue  
 gr = grey  
 li = purple  
 ge = yellow  
 or = orange

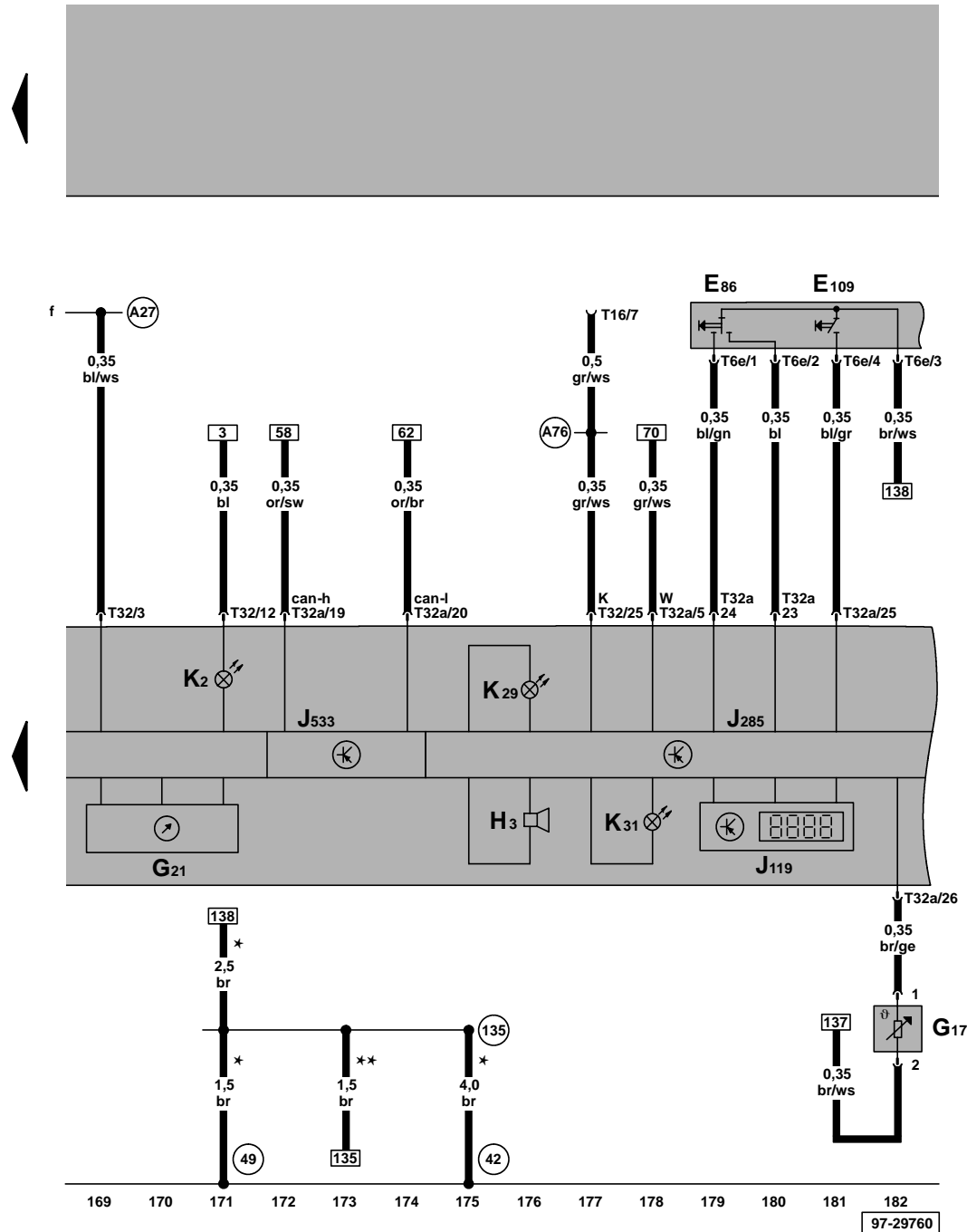

97-29760