

Anti-locking brake system (ABS), Anti-locking brake system (ABS) with electronic differential lock (EDL),

from October 1997

For alternatives to relay and fuse positions as well as multi-pin connector wiring-see "Fitting locations" section.

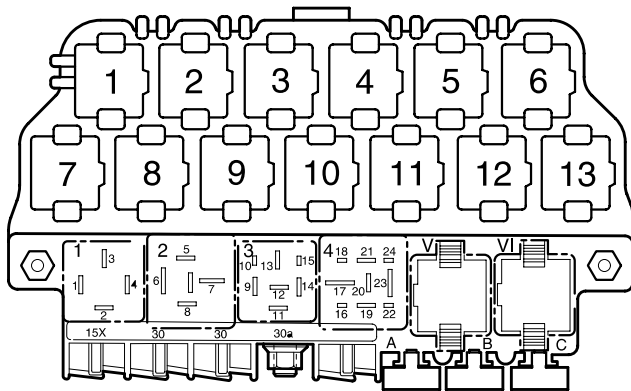

97-14163

Fuse colours

- 30 A – green
- 25 A – white
- 20 A – yellow
- 15 A – blue
- 10 A – red
- 7.5 A – brown
- 5 A – beige
- 3 A – lilac

ABS control unit, brake light switch

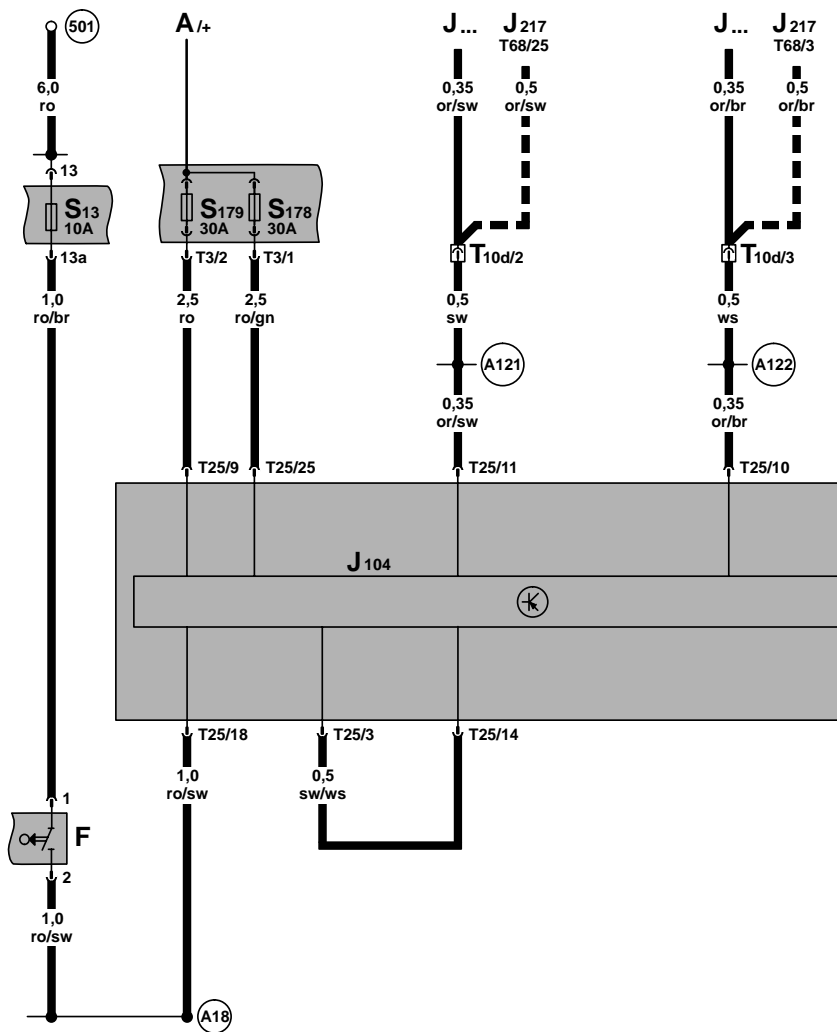

- A - Battery
- F - Brake light switch
- J104 - ABS with EDL control unit, left in engine compartment
- J217 - Automatic gearbox control unit, centre in plenum chamber
- J... - Engine control unit
- S13 - Fuse in relay plate fuse box
- S178 - Fuse -6- (30) in battery fuse holder
- S179 - Fuse -7- (30) in battery fuse holder
- T3 - 3-pin connector
- T10d - 10-pin connector, green, in protective housing for connectors, left in plenum chamber
- T25 - 25-pin connector
- T68 - 68-pin connector
- (501) - Screw connection -2- (30), on relay plate
- (A18) - Connection (54), in dash panel wiring harness
- (A121) - Connection (high bus), in dash panel wiring harness
- (A122) - Connection (low bus), in dash panel wiring harness

--- -For vehicles with automatic gearbox only

ws = white
 sw = black
 ro = red
 br = brown
 gn = green
 bl = blue
 gr = grey
 li = lilac
 ge = yellow
 or = orange

1 2 3 4 5 6 7 8 9 10 11 12 13 14

97-26773

Control unit for ABS with EDL, ABS warning lamp, ABS hydraulic pump

- D - Ignition/starter switch
- J104 - ABS with EDL control unit, left in engine compartment
- J285 - Control unit with display in dash panel insert
- J503 - Control unit with display for radio and navigation**
- K47 - ABS warning lamp
- N125 - Differential lock valve 1*
- N126 - Differential lock valve 2*
- N133 - ABS inlet valve, rear right
- N134 - ABS inlet valve, rear left
- N135 - ABS outlet valve, rear right
- N136 - ABS outlet valve, rear left
- S9 - Fuse in relay plate fuse box
- T2 - 2-pin connector
- T16 - 16-pin connector, centre in dash panel, self-diagnosis connection
- T25 - 25-pin connector
- T26 - 26-pin connector**
- T32 - 32-pin connector, blue
- V64 - ABS hydraulic pump

- (A76) - Connection (diagnosis wire K), in dash panel wiring harness
- (A80) - Connection -1- (X), in dash panel wiring harness
- (A133) - Connection (ABS impulse left), in dash panel wiring harness
- (A134) - Connection (ABS impulse right), in dash panel wiring harness
- * - For vehicles with EDL/TCS only
- ** - For vehicles with navigation system only

ws = white
 sw = black
 ro = red
 br = brown
 gn = green
 bl = blue
 gr = grey
 li = lilac
 ge = yellow
 or = orange

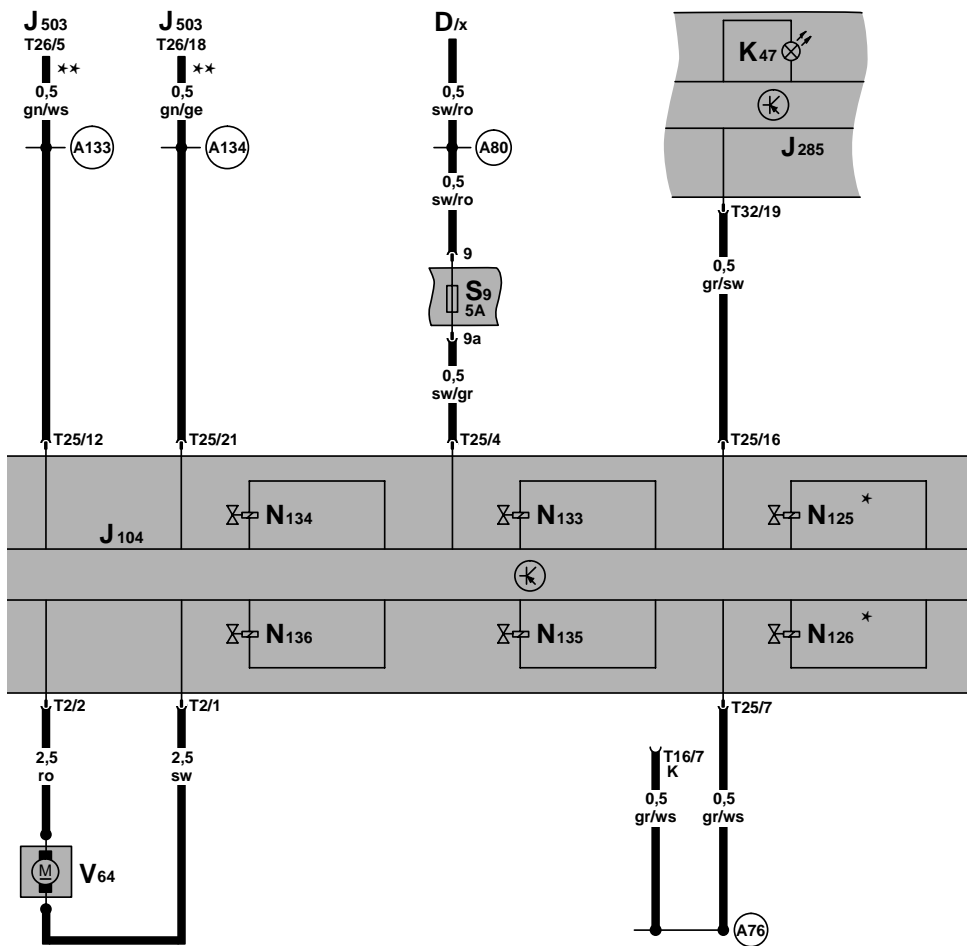

Control unit for ABS with EDL, speed sensors

- G44 - Rear right speed sensor
- G45 - Front right speed sensor
- G46 - Rear left speed sensor
- G47 - Front left speed sensor
- J104 - ABS with EDL control unit, left in engine compartment
- N99 - ABS inlet valve, front right
- N100 - ABS outlet valve, front right
- N101 - ABS inlet valve, front left
- N102 - ABS outlet valve, front left
- T2a - 2-pin connector, near rear right speed sensor
- T2b - 2-pin connector, near rear left speed sensor
- T25 - 25-pin connector

- (65) - Earth point, longitudinal member left, front
- (100) - Earth connection -1-, in ABS wiring harness
- (D146) - Connection (rear left speed sensor +), in engine compartment wiring harness
- (D147) - Connection (rear left speed sensor +), in engine compartment wiring harness
- (D148) - Connection (rear right speed sensor +), in engine compartment wiring harness
- (D149) - Connection (rear right speed sensor +), in engine compartment wiring harness

- ws = white
- sw = black
- ro = red
- br = brown
- gn = green
- bl = blue
- gr = grey
- li = lilac
- ge = yellow
- or = orange

